

METERING - SECONDARY

• Contents - Metering	M-1
• General Requirements for Metering	M-2, M-3
• Meter Socket Mounting.....	M-4
• Guards for Outdoor Installations.....	M-5
Metering Installations For Secondary Services:	
Meter Socket with Overhead Service Entrance:	
• 1Ø, 2-Wire Service, all voltages, 0-100 Amperes.....	M-6
• 1Ø, 3-Wire Service, 120/240 Volts, 0-320 Amperes.....	M-7
208Y/120 Volts, 0-100 Amperes.....	M-8
• 3Ø, 3-Wire Service, 240 Volts, 0-200 Amperes.....	M-8
480 Volts, 0-200 Amperes	M-9
• 3Ø, 4-Wire Service, 208Y/120 Volts, 480Y/277 Volts, 0-200 Amperes.....	M-10
Meter Socket for Customer Owned Street Lighting:	
• 1Ø, 3-Wire Service, 120/240 or 240/480 Volts, 0-200 Amperes.....	M-11
Meter Pedestal with Underground Service Lateral:	
• 1Ø, 2-Wire Service, 120 Volts, 0-30 Amperes.....	M-12
• 1Ø, 3-Wire Service, 120/240 or 240/480 Volts, 0-200 Amperes.....	M-13
120/240 Volts, 201-320 Amperes.....	M-14
208Y/120 Volts, 0-100 Amperes	M-15
• 3Ø, 3-Wire Service, 240 or 480 Volts, 0-200 Amperes.....	M-15
• 3Ø, 4-Wire Service, 208Y/120 Volts or 480Y/277 Volts, 0-200 Amperes.....	M-16
Meter Socket with Underground Service Lateral:	
• 1Ø, 3-Wire Service, 120/240 Volts, 0-200 Amperes.....	M-17
208Y/120 Volts, 0-100 Amperes.....	M-18
• 3Ø, 3-Wire Service, 240 or 480 Volts, 0-200 Amperes.....	M-18
• 3Ø, 4-Wire Service, 208Y/120 Volts or 480Y/277 Volts, 0-200 Amperes.....	M-19
Transocket with Overhead Service Entrance:	
• 1Ø, 3-Wire, 120/240 Volts, 201-800 Amperes, All 3Ø Voltages, 201-2000 Amperes	M-20
Transocket with Underground Service Lateral:	
• 1Ø, 3-Wire, 120/240 Volts, 201-800 Amperes, All 3Ø Voltages, 201-2000 Amperes	
• 3Ø, 4-Wire, 208Y/120 Volts or 480Y/277 Volts, 201-3000 Amperes.....	M-21
Outdoor Current Transformer Metering (Transocket) with Customer Disconnect	
• 1Ø, 3 Wire, 120/240 Volts, 201-800 Amperes, All 3Ø Voltages, 201-1200 Amperes.....	M-22
Meter Stack Socket Breaker Installation:	
• All Voltages, 0-200 Amperes per Meter.....	M-23
Current Transformer Metering in Free Standing Switchgear (Indoor):	
• All Voltages	M-24, M-25
Modular Metering (Indoor):	
• 1Ø, 3-Wire, 120/240 Volts, 208Y/120 Volts, All 3Ø Voltages, 0-200 Amperes per Meter	M-26

GENERAL REQUIREMENTS FOR METERING

General

The information covered in this section is applicable to overhead, underground, substation, and AC network sources of supply covered in the foregoing sections of the manual.

Location of Meters and Metering Equipment

1. Outdoor metering is required for residential, one or two customer, and farm installations with 1-phase service of 200 amperes or less.
2. Meters shall be installed outdoors in cases such as summer dwellings and other premises not occupied during the entire year or not accessible during regular working hours of Company personnel.
3. For outdoor installations with an OH service drop, the centerline of all meters shall be between 4 and 6 feet from the finished grade.
4. For outdoor installations with an UG service lateral, the centerline of all meters shall be between 3 and 6 feet from the finished grade.
5. For indoor installations, locate meters in the basement or other suitable and readily accessible place as near as possible to the point where the service enters the building. The centerline of all meters shall be between 4 and 6 feet above the floor (not applicable to ganged or grouped installations of more than 2 units as covered in 6 below).
6. For indoor group installations the centerline of all meters shall be between 2 and 6 feet above the floor. For apartment, commercial and other appropriate buildings of more than 2 floors, meters may be located on the different floors of the building provided they are grouped in enclosures as near as practicable to the risers serving the floors and the wiring and metering layout for the building is accepted by the Company.
7. For multiple unit buildings (two or more), each meter position shall be marked on the outside of the socket or by the breaker (if available) with the address of the unit served. If the marking is on outside of the removable cover, it shall also be marked on the inside of the meter socket in a visible location. This marking shall also be placed on the corresponding distribution panel(s). The marking shall be a permanent label with 1/2" block letters and may consist of individual self-stick letters or numbers, suitable for the location so as to be considered permanent.
8. There shall be a 3' minimum of unobstructed working space, measured from the meter face, in front of all meters. This space shall extend from the floor or grade to a height of 6'-6". At least one entrance of sufficient area shall be provided to give access to this working space.
9. The unobstructed space required in front of meter cabinets, current transformer compartments, and transformer loss compensation cabinets shall be as defined by the "Working Space About Electrical Equipment" section 110.26 of the **National Electrical Code** (latest revision as adopted by the states of Michigan and Wisconsin). This unobstructed space shall extend from the floor or ground to a height of 6'-6". Equipment doors are required by the NEC to open a minimum of 90°.
10. Ample space shall be provided for all meters, metering equipment, and other apparatus so that they can be safely read, inspected, and tested. Meter equipment shall not be located:
 - a. In animal enclosures, attics, closets, elevator or ventilating shafts, hallways, living quarters, stairways, or rooms containing corrosive or explosive vapors (battery rooms).
 - b. Near stoves, radiators, steam or hot water pipes, or within 5' of moving machinery.
 - c. Above laundry equipment, plumbing fixtures or other bulky equipment.
 - d. Behind shrubbery or swinging doors, or over alleys, driveways, decks or porches (or over sidewalks where practicable), or where it is necessary to trespass on adjacent property.
 - e. In hazardous locations as defined in articles 500 to 516 of the **National Electric Code** as amended in Michigan by the **Michigan Administrative Code** and as amended in Wisconsin by the **Wisconsin Administrative Code**.
 - f. Where subject to damage from falling ice, snow or other debris. If the metering equipment cannot be moved to an area free of these hazards the necessary protection may be provided by a roof overhang or gutter that extends a minimum of 12" past the face of the meter socket. In place of the roof overhang the customer shall provide and install a deflector that shall extend 12" past the face of the meter socket and be installed at a height greater than 6'-6" to comply with Notes 8 & 9 above.
11. Meter locations shall be free from excessive moisture, vibrations, and heat. Meters shall not be placed on partitions, insecure walls or over doorways. Meters shall be shielded from magnetic disturbances and protected from mechanical damage, moving machinery and belts by means of a suitable protecting cabinet.
12. 3' horizontal clearance between gas and electric metering equipment should be provided.

Methods of Mounting Metering Equipment

1. Socket-type meter mounting devices installed on concrete or masonry walls shall be fastened by non-corrosive metal machine screws in lead sleeve, wedge-type expansion anchors.
2. All mounting devices for metering equipment shall be plumb.

Methods of Wiring Service Equipment and Meters

1. On outdoor installations, the knockouts of meter sockets, transockets, or meter pedestals shall not be used for service entrance conductors unless the knockouts are located entirely below the lowest live parts.
2. Metered and unmetered conductors shall not be installed in the same conduit, wiring trough, channel, gutter or similar enclosure.
3. Where a group of meters is supplied from a service raceway, the covers of the raceway must be provided with a means for sealing where individual service taps are made into the raceway.
4. Termination compartments, meter mounting devices or current transformer compartments shall not be used as junction boxes for additional customer circuit connections.
 - a. This includes taps for emergency circuits or fire alarms.
 - b. At single metered installations where 2 to 6 disconnects are used in place of a single main disconnect, a customer owned junction box or switchboard section shall be installed on the load side of all Company facilities for the purpose of making taps to the individual disconnects.
 - c. Customer provided termination compartments and transockets are permitted to have up to 2 circuits exiting them.
5. Sockets shall be equipped with blank covers furnished by the customer at the time of installation.
6. The rating of a single service switch or the combined rating of all service switches connected to a 1-phase 120/240 volt service shall not exceed 400 amperes unless accepted by the Company.
7. A common grounding conductor shall be used to ground the service entrance equipment and the grounded circuit conductor. A grounding conductor shall not be run from the meter socket to ground or through the meter socket, termination compartment or transocket in going from the customer's main service switch or disconnect means to ground. Direct grounding of meter sockets is permissible, only on meter poles where the disconnecting means is installed at some other location. For multi-metered installations the grounding electrode conductor may be bonded to the neutral in a termination compartment.
8. Service switches or service breakers shall be installed so that any one service switch or breaker, when disconnected, shall not interrupt continuity of service to any other separately metered customer on the premises.
9. All large installations not covered by this Metering Section require special consideration and the Company shall be consulted in all cases. The customer shall submit 3 drawings of the proposed service equipment and metering arrangement to the local Company office for acceptance.
10. Any service entrance that serves a 24-hour load, 30 days each month of 150 amperes or more, shall have a current transformer metering installation.
11. Any fire pump service where the Full Load Running Amperage (FLRA) of the pump(s) exceeds 125 Amperes shall have a current transformer metering installation.
12. On outdoor current transformer installations the meter cabinet and conduit shall be grounded, either by bonding to the service entrance conduit or bus duct.
13. The Company shall meter only those voltages supplied to the customer by the Company; there will be no Company metering after a customer-owned stepdown transformer.
14. On new installations it is the customer's responsibility to ensure that the meter stops or grounding brackets are clean and provide for a good electrical contact with the meter base.
15. Multi-metered installations shall be installed so as to balance the load on the service.
16. For Communication Tower Policy and Service Termination see pages U-32 and U-33.

METER SOCKET MOUNTING

Customer furnishes and installs:

1. Company listed meter socket.
2. Galvanized bolts, nuts and washers for mounting meter socket.
3. Galvanized thinwall spacers. They must be as long as the thickness of the finished wall, such as siding, brick or stone (see Note 1).
4. Horizontally mounted 2"x 4" wood supports or #11 gauge minimum thickness steel plates.
5. Studding for the building wall.

Company furnishes and installs:

6. Watthour meter.

Note:

1. The meter socket is to be so installed that it will be securely and permanently mounted both before and after the finished wall is installed. The meter will not be installed until the socket is so mounted.

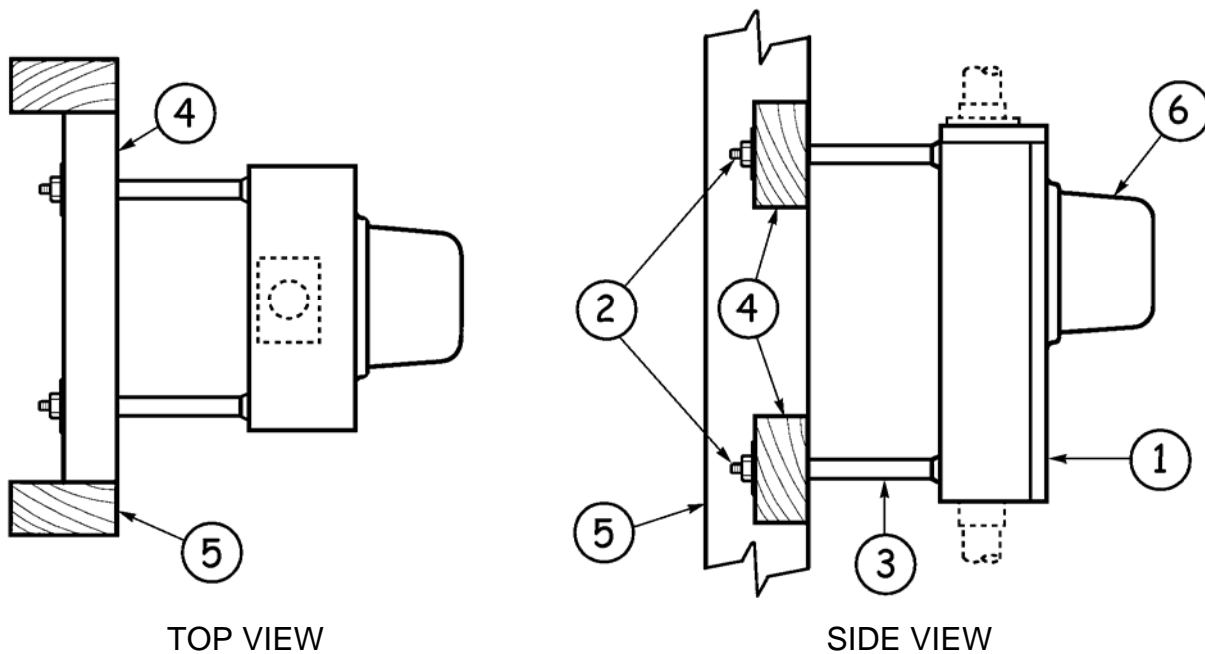

GUARDS FOR OUTDOOR INSTALLATIONS

Customer furnishes and installs:

1. Galvanized steel pipe, schedule 40, 3-1/2" diameter by 6'-6" minimum length and filled with concrete. Approximately 3.4 cu. ft. of concrete is required for the foundation and filling the pipe (see Note 1).
2. Galvanized steel pipe, schedule 40, 6" diameter by 8' minimum length and filled with concrete. Approximately 4 cu. ft. of concrete is required for the foundation and filling the pipe (see Note 1).
3. Concrete footing. A Sono tube is recommended to prevent heaving due to frost.

Notes:

1. The Company shall be consulted concerning the type, placement and number of guards required.

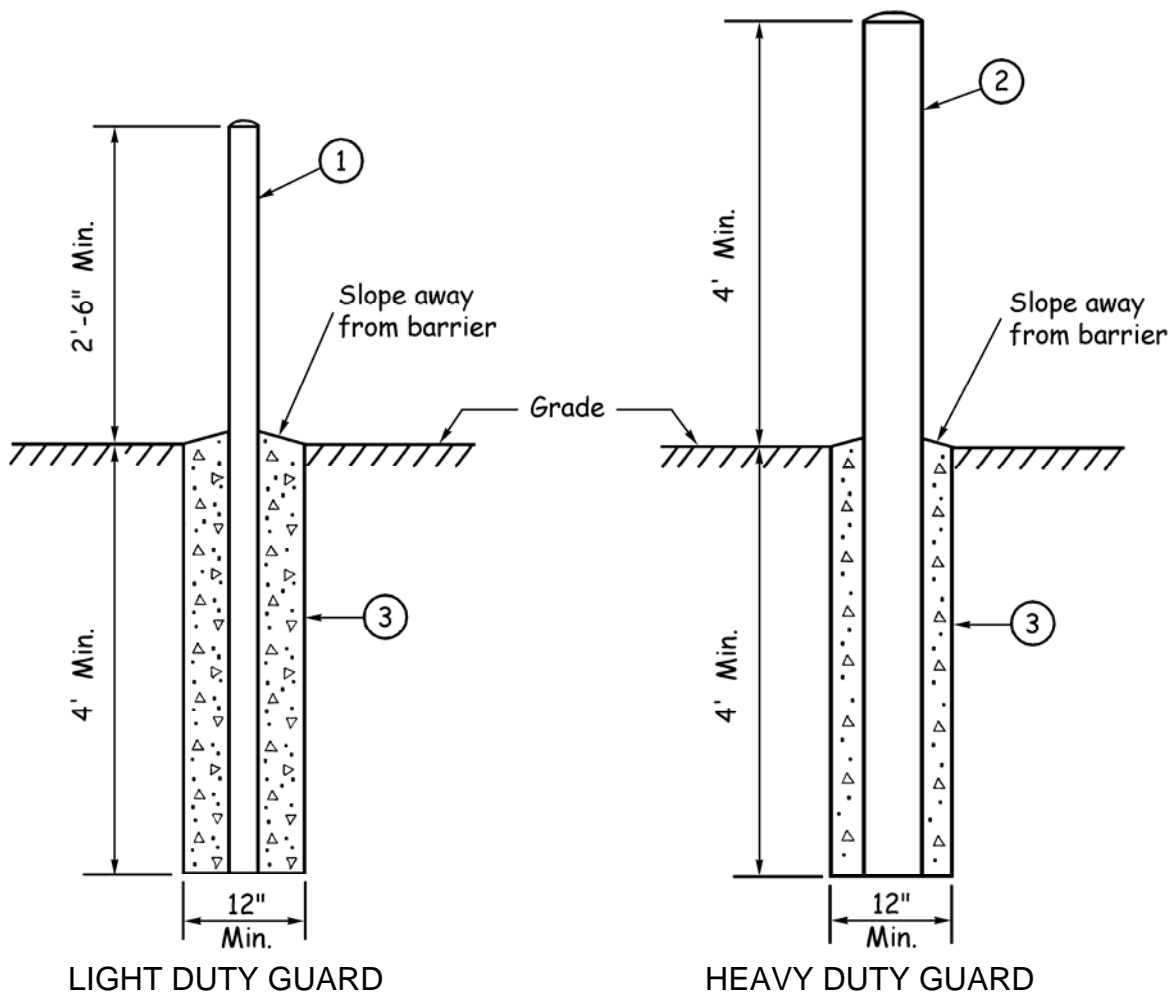

METER SOCKET WITH OVERHEAD SERVICE ENTRANCE
1-PHASE, 2-WIRE, 120 VOLTS, 0-30 AMPERES²
1-PHASE, 2-WIRE, 277 VOLTS, 0-60 AMPERES
1-PHASE, 2-WIRE, 240^{3,4} OR 480 VOLTS (UNGROUND⁴ED)⁴, 0-100 AMPERES
METERING SEQUENCE: METER-SWITCH-FUSE

Customer furnishes and installs:

1. Conduit and conductors.
2. Water-tight hub.
3. Company listed 4-terminal meter socket
(see Note 1 and Sheets D-3 & D-5).
4. Metallic conduit shall be bonded to the meter socket.

**Company furnishes and installs the
Watt-hour meter.**

Note:

1. Provide 4" clearance around meter from all foreign objects.
2. When supplied from a 1-phase, 3-wire, 120/240 volt grounded system or a 3-phase, 4-wire, 208Y/120 volt grounded radial system.
3. When supplied from a 3-phase, 3-wire, 240 volt grounded system.
4. For maintenance only.

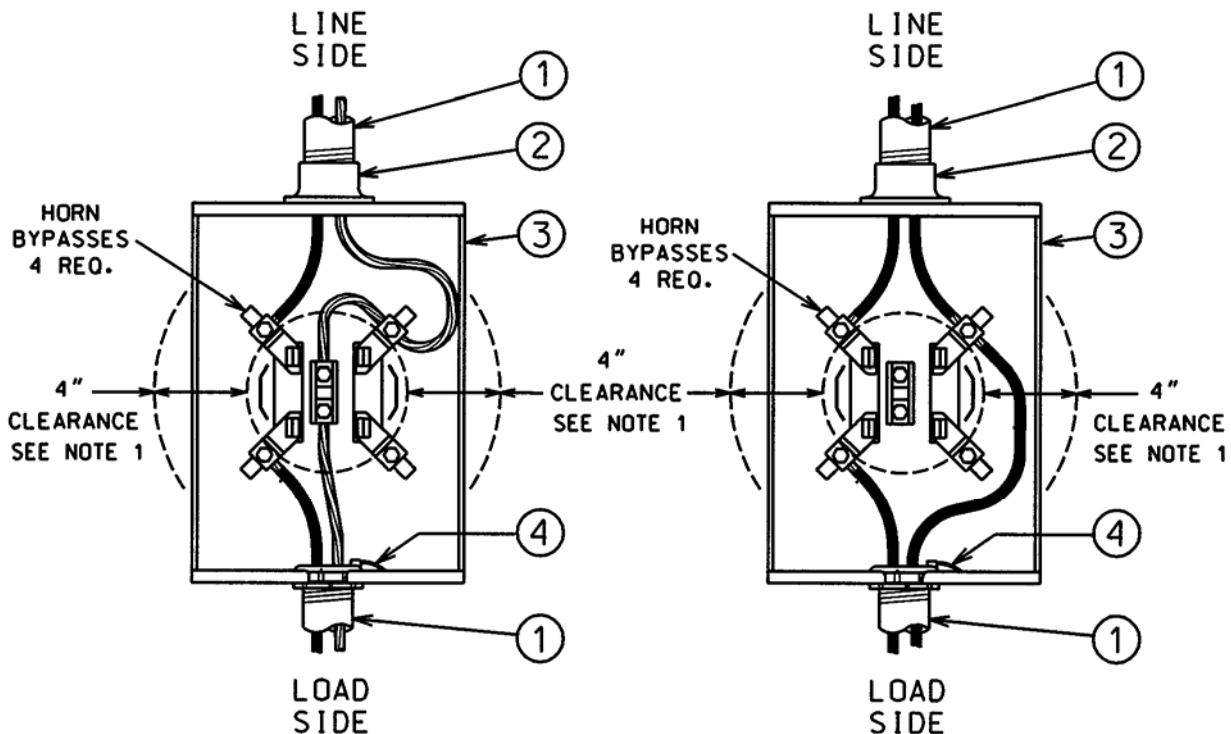

120, 240 or 277 VOLTS

480 (UNGROUND⁴ED)

METER SOCKET WITH OVERHEAD SERVICE ENTRANCE
1-PHASE, 3-WIRE, 120/240 VOLTS, 0-320 AMPERES
METERING SEQUENCE: METER-SWITCH-FUSE

Customer furnishes and installs:

1. Conduit and conductors.
2. Water-tight hub.
3. Company listed 4-terminal meter socket
(see Note 1 and Sheets D-3 & D-5).
4. Metallic conduit shall be bonded to the meter socket.

**Company furnishes and installs the
Watt-hour meter.**

Note:

1. Provide 4" clearance around meter from all foreign objects.

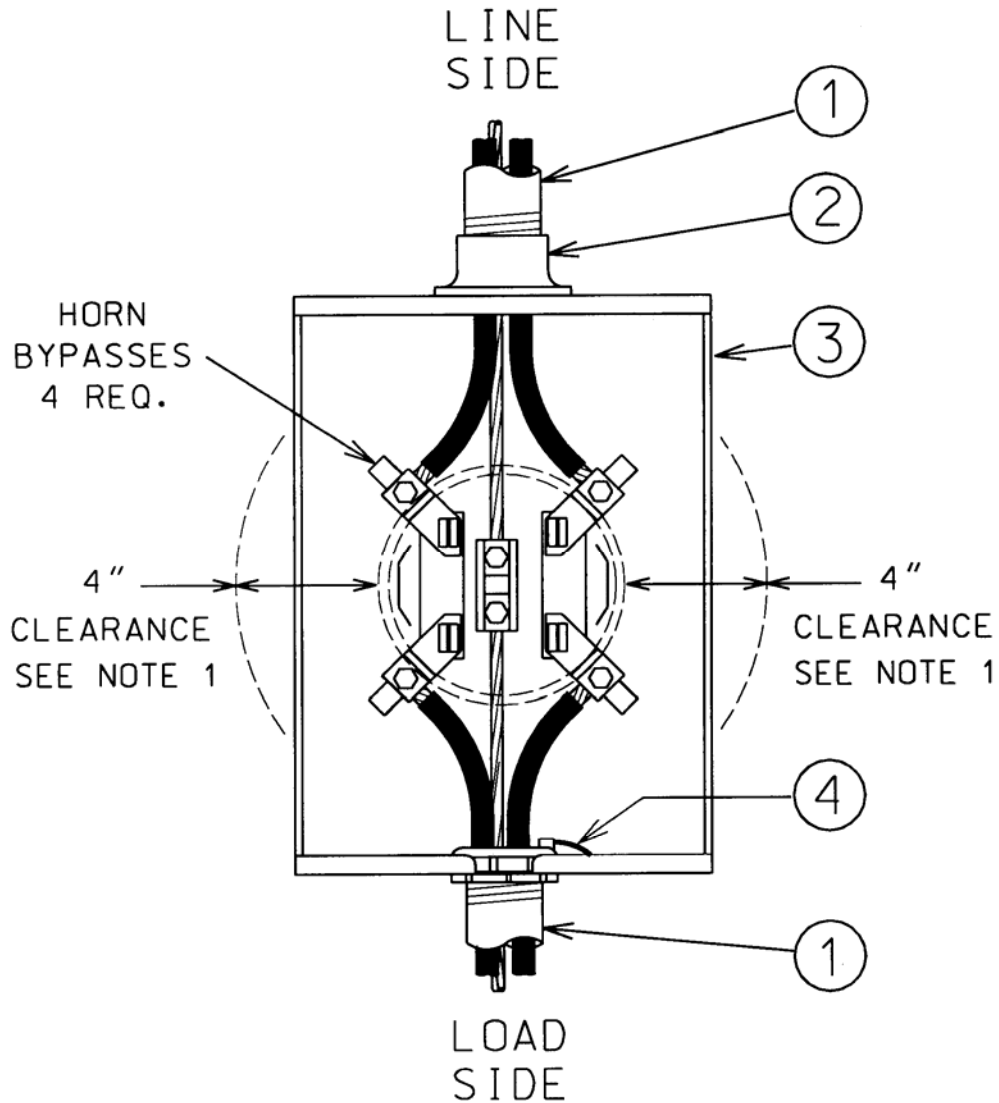

METER SOCKET WITH OVERHEAD SERVICE ENTRANCE
1-PHASE, 3-WIRE, 208Y/120 VOLTS, 0-100 AMPERES*
3-PHASE, 3-WIRE, 240 VOLTS, 0-200 AMPERES
METERING SEQUENCE: METER-SWITCH-FUSE (See Note 3)

Customer furnishes and installs:

1. Conduit and conductors.
2. Water-tight hub.
3. Company listed 5-terminal meter socket (see Note 1 and Sheet D-4).
4. Metallic conduit shall be bonded to the meter socket.
5. 5th terminal. May be in the 6 or 9 o'clock position (see Note 2).

**Company furnishes and installs the
Watt-hour meter.**

Notes:

1. Provide 4" clearance around meter from all foreign objects.
2. If the potential tap from the neutral conductor to the 5th terminal is not supplied by the manufacturer it shall be a #14 white insulated wire.
3. SW-F-M sequence is required for 208Y/120 Volt, AC network (downtown Milwaukee area), services located indoors.

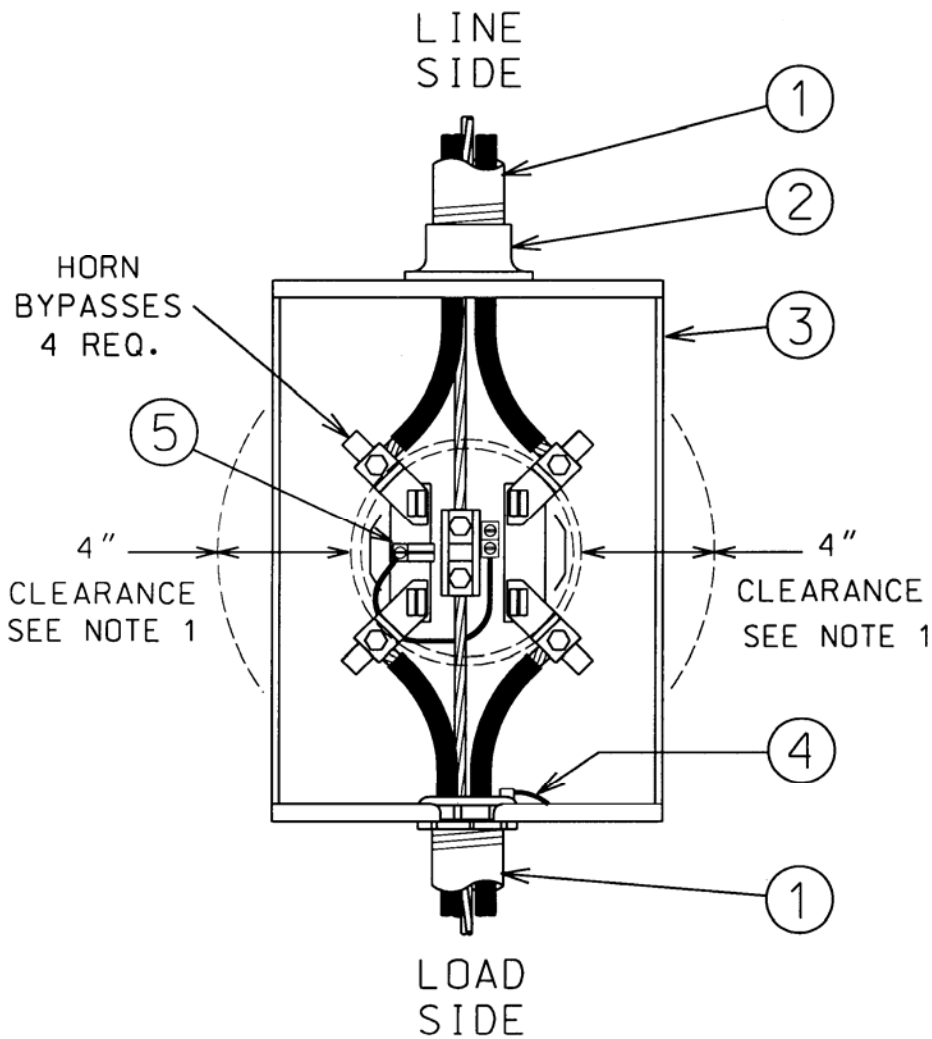

*2 phase wires and a neutral supplied from a 3-phase, 4-wire, 208Y/120 volt grounded system.

**METER SOCKET WITH OVERHEAD SERVICE ENTRANCE
3-PHASE, 3-WIRE, 480 VOLTS (UNGROUND), 0-200 AMPERES
METERING SEQUENCE: METER-SWITCH-FUSE**

Customer furnishes and installs:

1. Company listed 5-terminal meter socket with center phase sliding link disconnect (see Note 1 and Sheet D-4).
2. Conduit and service entrance conductors.
3. Water-tight hub.
4. Metallic conduit shall be bonded to the meter socket.
5. 5th terminal. May be in the 6 or 9 o'clock position (6 o'clock shown, see Note 2).

**Company furnishes and installs the
Watt-hour meter.**

Notes:

1. Provide 4" clearance around meter from all foreign objects.
2. When the 5th terminal is in the 9 o'clock position and the potential tap wire from the center phase to the 5th terminal is not provided by the manufacturer a #14 black insulated wire shall be installed.

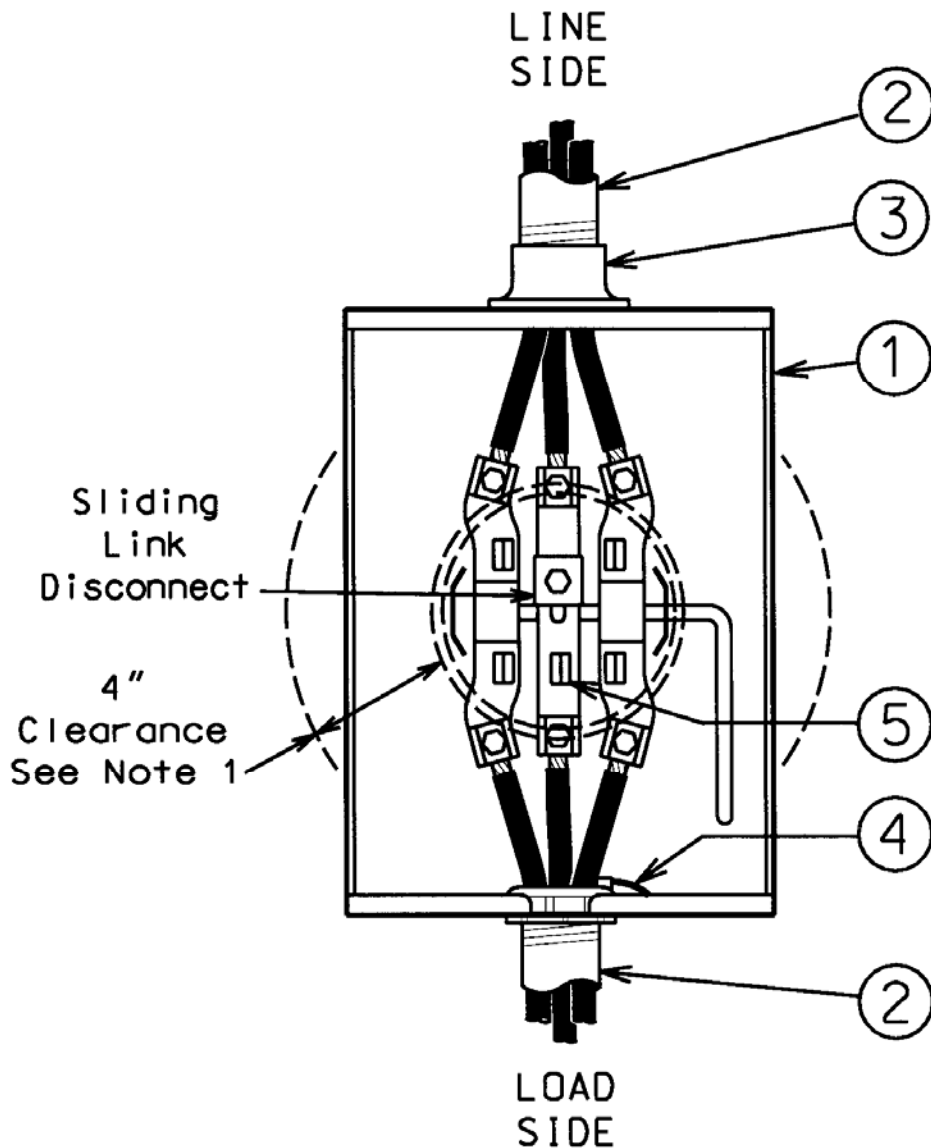

METER SOCKET WITH OVERHEAD SERVICE ENTRANCE
3-PHASE, 4-WIRE, 208Y/120 OR 480Y/277 VOLTS, 0-200 AMPERES
METERING SEQUENCE: METER-SWITCH-FUSE (See Note 3)

Customer furnishes and installs:

1. Conduit and conductors.
2. Water-tight hub.
3. Company listed 7-terminal meter socket (see Note 1 and Sheet D-4).
4. 7th terminal with potential tap (see Note 2).
5. Metallic conduit shall be bonded to the meter socket.

**Company furnishes and installs the
Watt-hour meter.**

Notes:

1. Provide 4" clearance around meter from all foreign objects.
2. If the potential tap from the neutral conductor to the 7th terminal is not provided by the manufacturer it shall be a #14 white insulated wire.
3. SW-F-M sequence is required for indoor, 208Y/120 Volt, AC network (downtown Milwaukee), services.

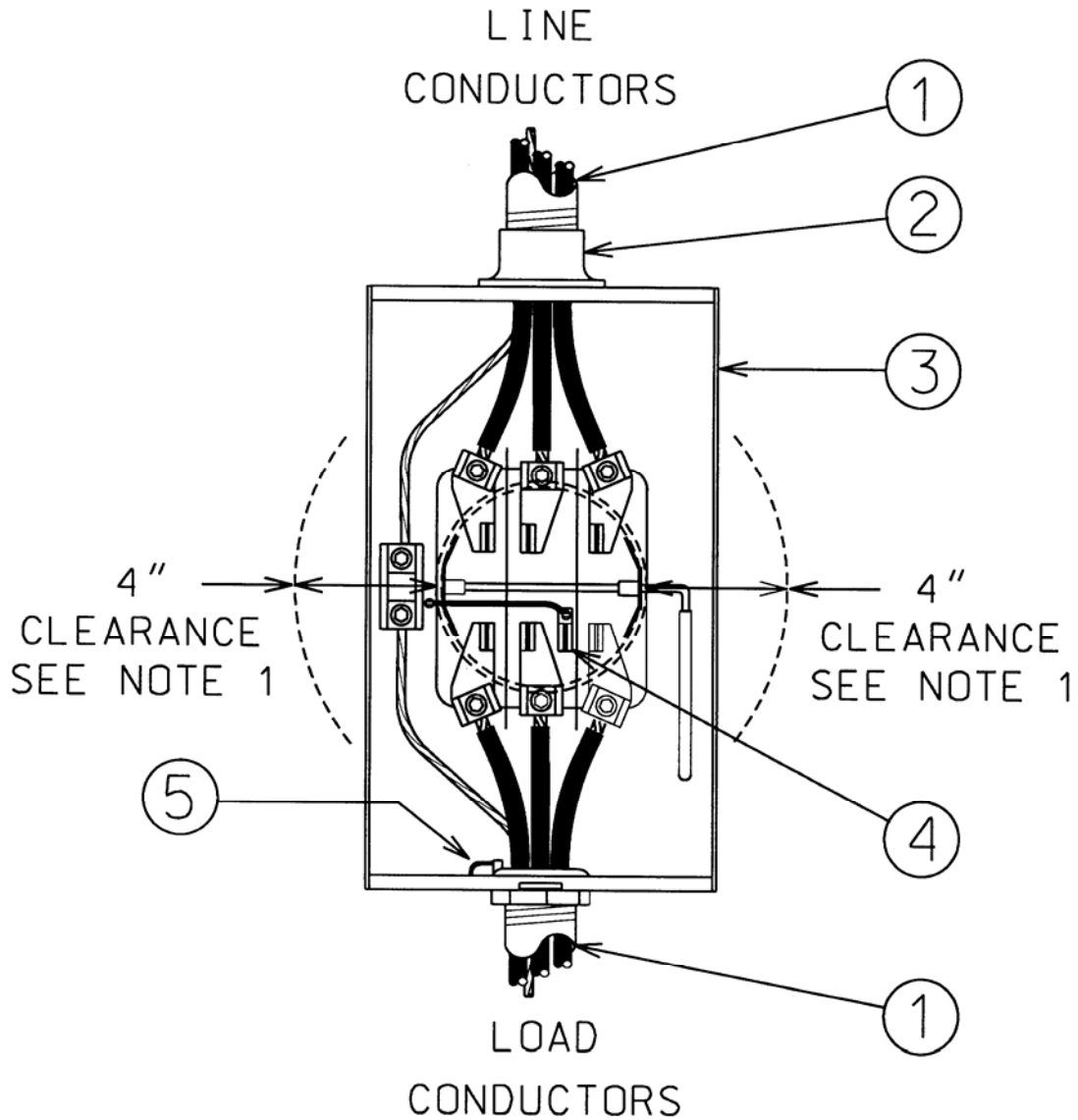

METER SOCKET FOR CUSTOMER OWNED STREET LIGHTING
1-PHASE, 3-WIRE, 240/480 VOLTS (GROUNDED), 0-200 AMPERES
METERING SEQUENCE: METER-SWITCH-FUSE

Customer furnishes and installs:

1. Conduit and conductors.
2. Water-tight hub.
3. Company listed 4-terminal meter socket
(see Note 1 and Sheet D-6).
4. Metallic conduit shall be bonded to the meter socket.

Company furnishes and installs the
Watt-hour meter.

Notes:

1. Provide 4" clearance around meter from all foreign objects.

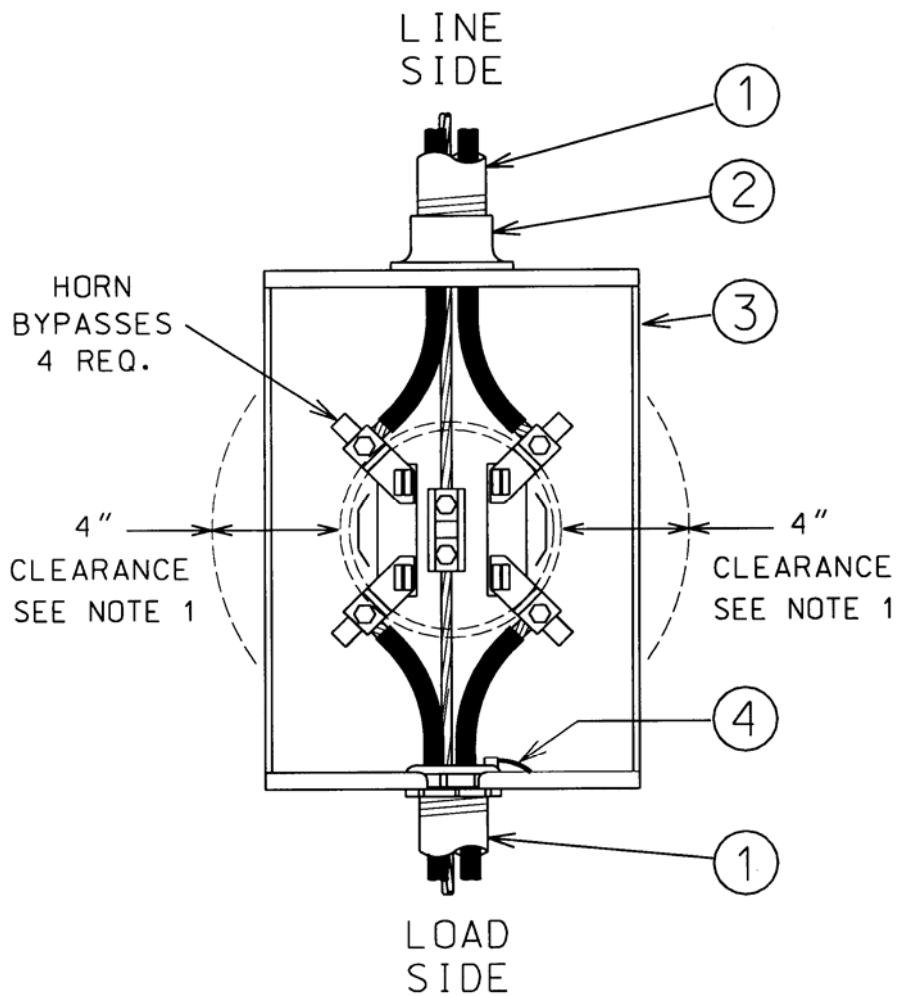

METER PEDESTAL WITH UNDERGROUND SERVICE LATERAL
1-PHASE, 2-WIRE, 120 VOLTS, 0-30 AMPERES
METERING SEQUENCE: METER-SWITCH-FUSE

Customer furnishes and installs:

1. Service-entrance conduit and conductors (see Note 1).
2. Company listed 4-terminal meter pedestal (see Note 2 and Sheets D-11 & D-12).
3. Metallic conduit shall be bonded to the meter pedestal.
4. Service-entrance conductor, neutral.
5. Service-entrance conductor, phase or hot wire.

Company furnishes and installs:

6. Service lateral.
7. Watthour meter (not shown).

Notes:

1. Service-entrance conductors must exit the pedestal below the lowest live part and above grade.
2. Provide 4" clearance around meter from all foreign objects.

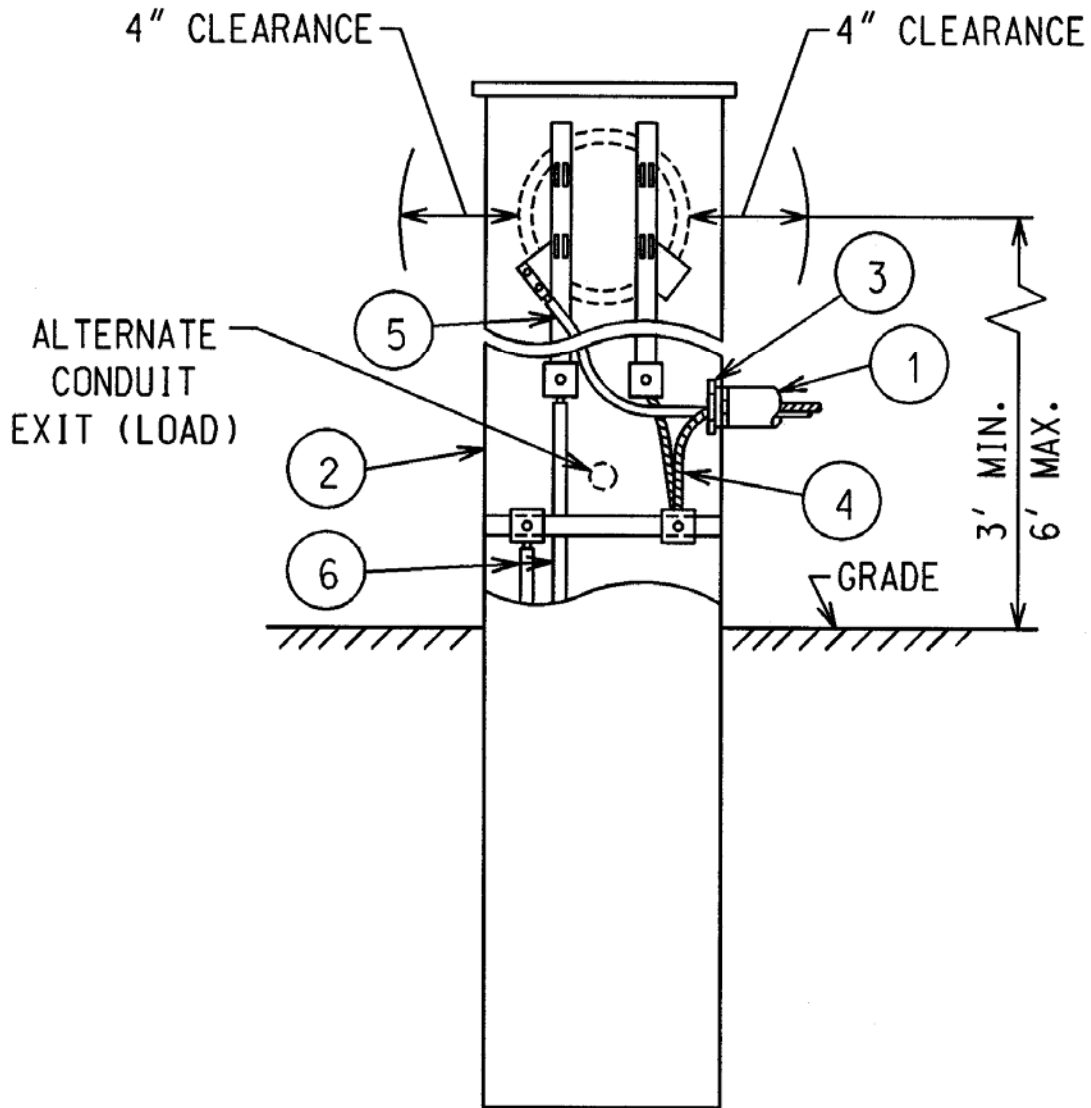

METER PEDESTAL WITH UNDERGROUND SERVICE LATERAL
1-PHASE, 3-WIRE, 120/240 or 240/480³ VOLTS, 0-200 AMPERES
METERING SEQUENCE: METER-SWITCH-FUSE

Customer furnishes and installs:

1. Service entrance conduit and conductors (see Note 1).
2. Company listed 4-terminal meter pedestal (see Note 2 and Sheets D-11 & 12).
3. Metallic conduit shall be bonded.

Company furnishes and installs:

4. Service lateral.
5. Watthour meter (not shown).

Notes:

1. Service entrance conductors must exit the pedestal below the lowest live part and above grade.
2. Provide 4" clearance around meter from all foreign objects.
3. For use with 240/480 Volt, 1Ø, 3 Wire service, the pedestal must be rated for 480 Volts or above.

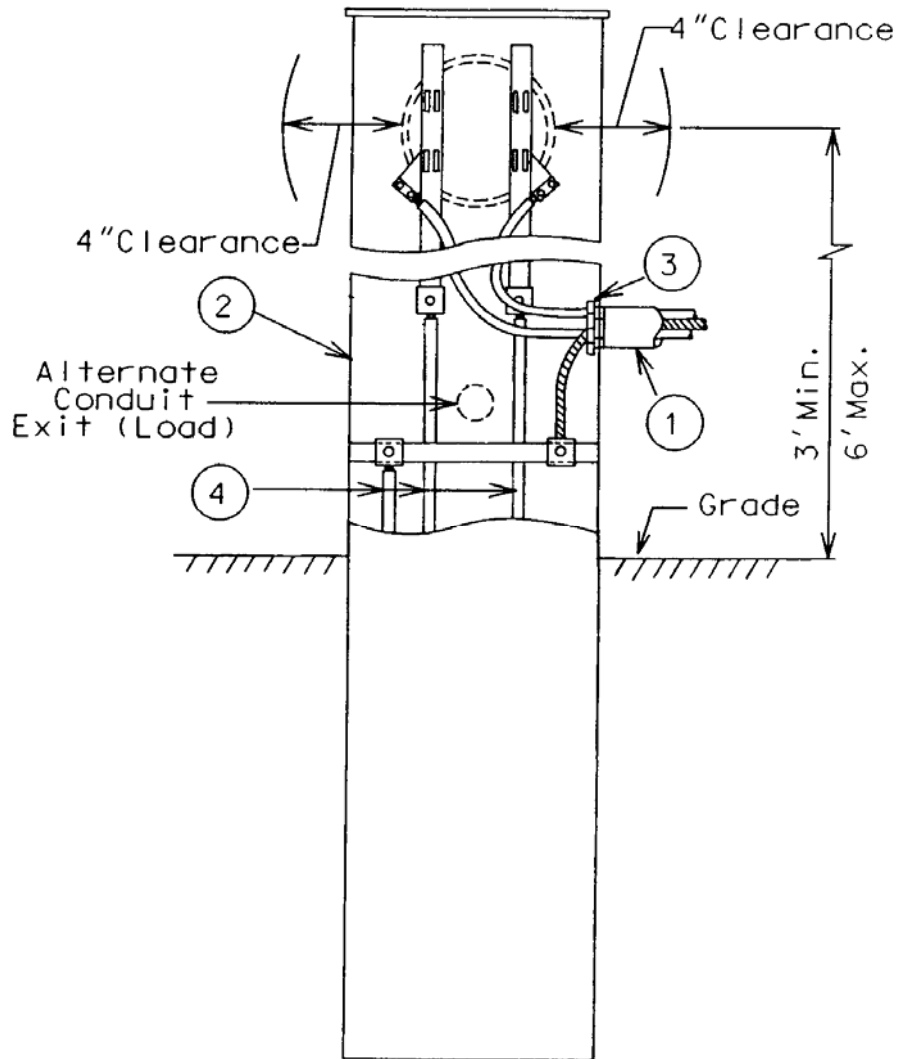

METER PEDESTAL WITH UNDERGROUND SERVICE LATERAL
1-PHASE, 3-WIRE, 208Y/120 VOLTS, 0-100 AMPERES*
3-PHASE, 3-WIRE, 240 OR 480 VOLTS (UNGROUND), 0-200 AMPERES
METERING SEQUENCE: METER-SWITCH-FUSE

Customer furnishes and installs:

1. Service entrance conduit and conductors (see Note 1).
2. Company listed 5-terminal meter pedestal (see Notes 2 & 3 and Sheet D-12).
3. Metallic conduit shall be bonded to the meter pedestal.
4. 5th terminal. 6 o'clock position for 480 Volt, all others to be in the 9 o'clock or (see Note 4).

Company furnishes and installs:

5. Service lateral.
6. Watthour meter (not shown).

Notes:

1. Service entrance conductors must exit the pedestal below the lowest live part and above grade.
2. Provide 4" clearance around meter from all foreign objects.
3. Meter pedestals used in 480 volt applications must be equipped with a center phase sliding link disconnect.
4. If the potential tap from the neutral conductor to the 5th terminal is not provided by the manufacturer it shall be a #14 white insulated wire for 208Y/120 Volts or a #14 black insulated wire for 480 Volts (ungrounded).

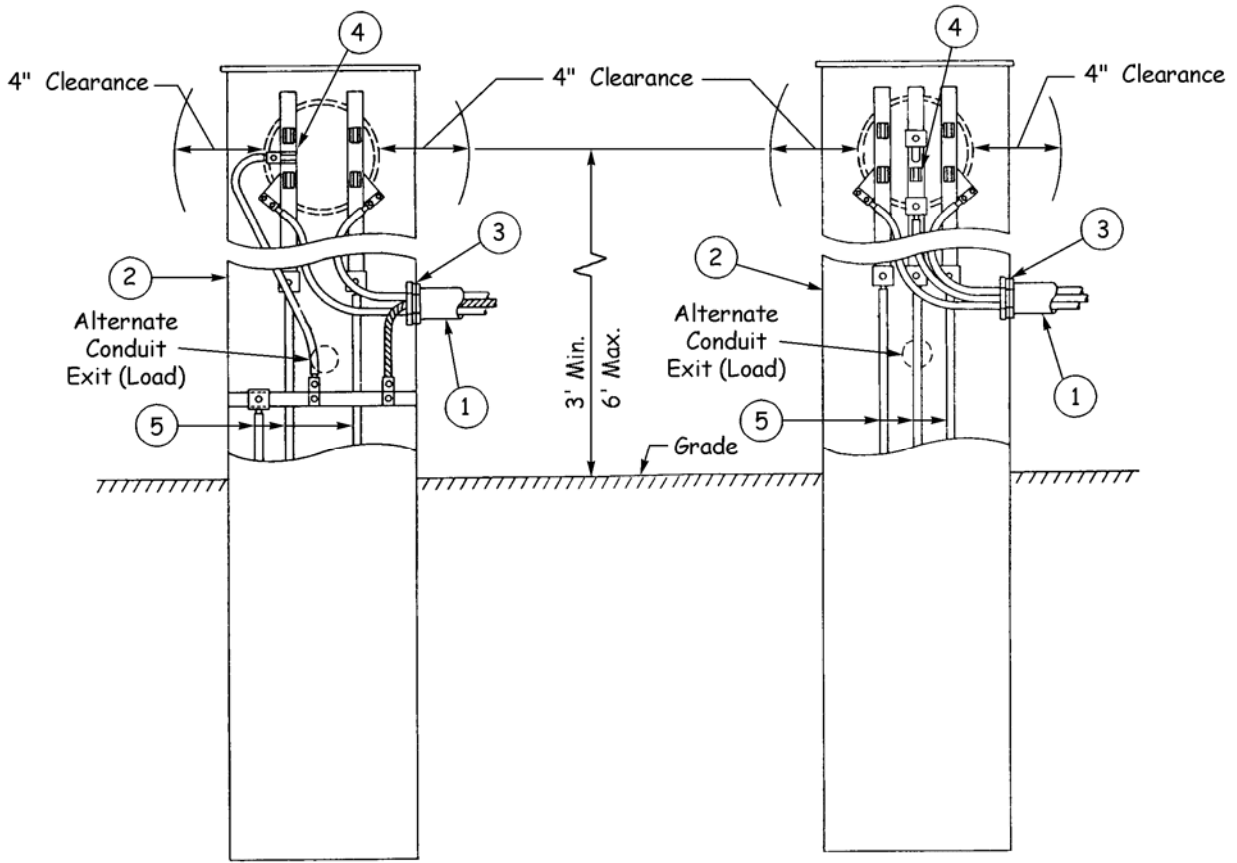

208/120 or 240 VOLTS

480 VOLTS (UNGROUND)

* 2 phase wires and a neutral supplied from a 3-phase,4-wire, 208Y/120 volt grounded system.

METER PEDESTAL WITH UNDERGROUND SERVICE LATERAL
3-PHASE, 4-WIRE, 208Y/120 OR 480Y/277 VOLTS, 0-200 AMPERES
METERING SEQUENCE: METER-SWITCH-FUSE (See Note 4)

Customer furnishes and installs:

1. Service entrance conduit and conductors (see Note 1).
2. Company listed 7-terminal meter pedestal (see Note 2 and Sheet D-12).
3. Metallic conduit shall be bonded to the meter pedestal.
4. 7th terminal with potential tap (see Note 3).

Company furnishes and installs:

5. Service lateral.
6. Watthour meter (not shown).

Notes:

1. Service entrance conductors must exit the pedestal below the lowest live part and above grade.
2. Provide 4" clearance around meter from all foreign objects.
3. If the potential tap from the neutral conductor to the 7th terminal is not provided by the manufacturer it shall be a #14 white insulated wire.
4. SW-F-M sequence is required for 208Y/120 Volt, AC network (downtown Milwaukee area), services located indoors.

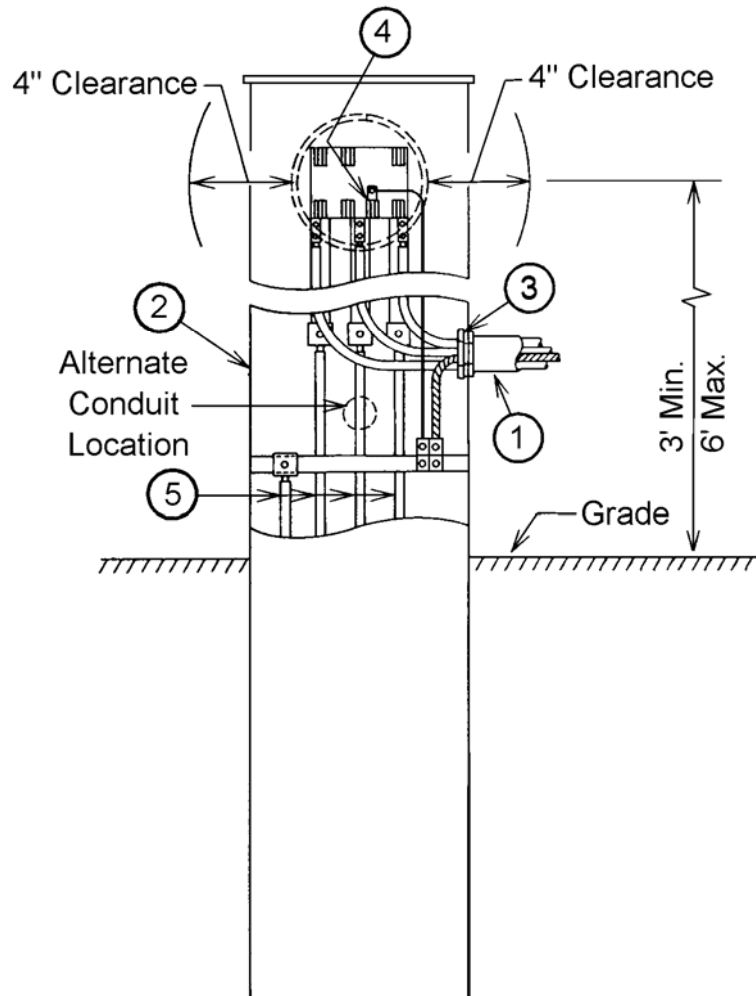

METER SOCKET WITH UNDERGROUND SERVICE LATERAL
1-PHASE, 3-WIRE, 120/240 VOLTS, 0-200 AMPERES
METERING SEQUENCE: METER-SWITCH-FUSE
Obtain acceptance for 1-phase installations from the Company.

Customer furnishes and installs:

1. Service entrance conduit and conductors (see Note 1).
2. Company listed 4-terminal meter socket (see Note 2 and Sheets D-7 & D-9).
3. Service lateral conduit.
4. Metallic conduit shall be bonded to the meter socket.

Company furnishes and installs:

5. Service lateral.
6. Watthour meter (not shown).

Notes:

1. For a 120 volt, 2-wire service, the service entrance conductors consist of the neutral conductor and one of the phase conductors.
2. Provide 4" clearance around meter from all foreign objects.

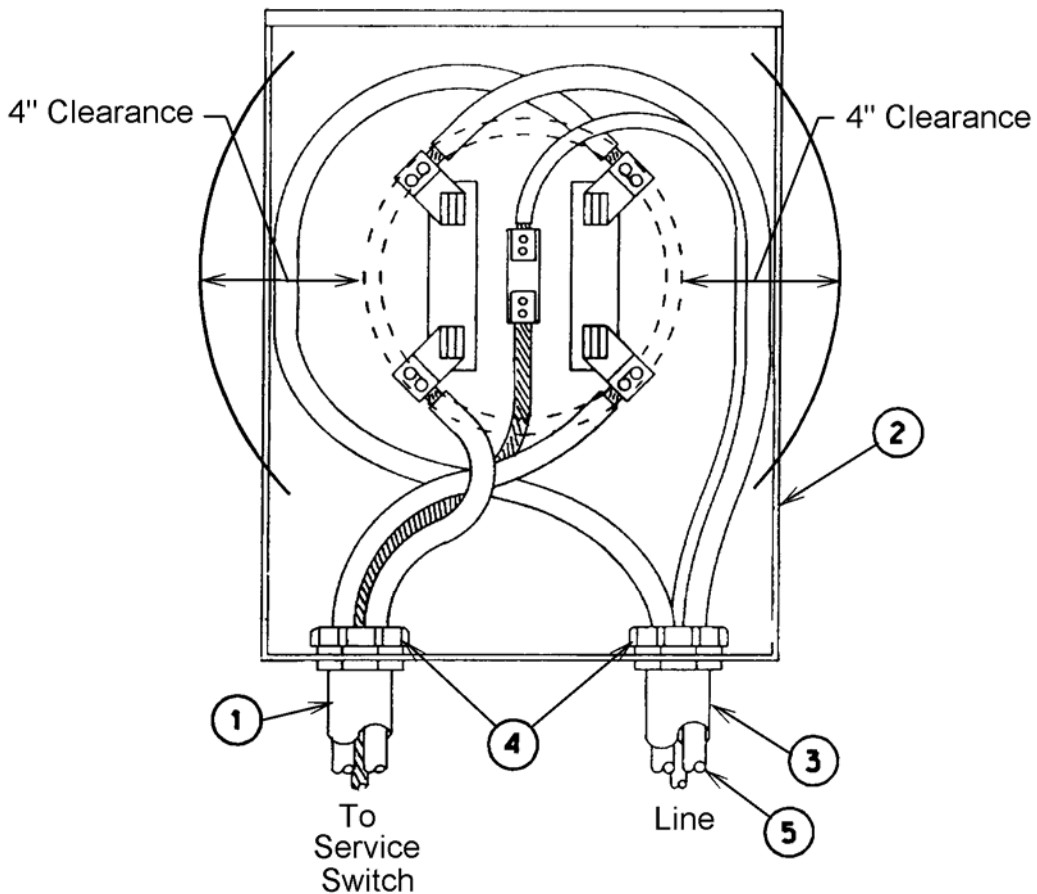

METER SOCKET WITH UNDERGROUND SERVICE LATERAL
1-PHASE, 3-WIRE, 208Y/120 VOLTS, 0-100 AMPERES*
3-PHASE, 3-WIRE, 240 VOLTS OR 480 VOLTS (UNGROUND), 0-200 AMPERES
METERING SEQUENCE: METER-SWITCH-FUSE (See Note 3)

Customer furnishes and installs:

1. Company listed 5-terminal meter socket (see Note 1 and sheets D-8 & D-9). Center phase disconnect is required for 480 volt applications.
2. Service entrance conduit and conductors.
3. Service lateral conduit.
4. 5th terminal (see Note 2).
5. Metallic conduit shall be bonded.

Company furnishes and installs:

6. Service lateral.
7. Watthour meter (not shown).

Notes:

1. Provide 4" clearance around meter from all foreign objects.
2. For 1-phase, 208Y/120 volt and 3-phase, 240 volt the 5th terminal shall be in the 9 o'clock position. If the potential tap from the 5th terminal to the grounded conductor is not provided by the manufacturer it shall be a #14 white insulated wire. For 480 volt the 5th terminal shall be in the 6 o'clock position. If the potential tap from the 5th terminal to the center phase conductor is not provided by the manufacturer it shall be a #14 black insulated wire.
3. SW-F-M sequence is required for indoor, 208Y/120 Volt, AC network (downtown Milwaukee), services.

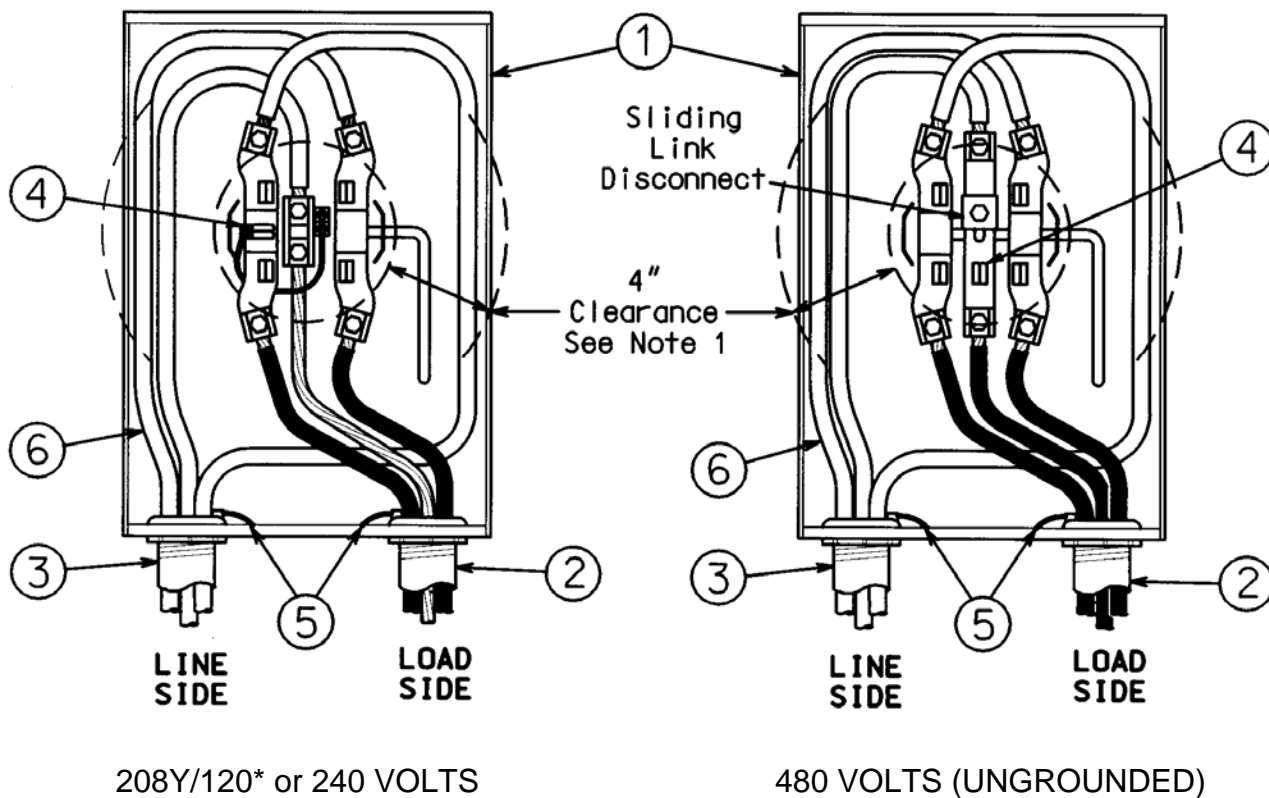

* 2 phase wires and a neutral supplied from a 3-phase, 4-wire, 208Y/120 volt grounded system.

METER SOCKET WITH UNDERGROUND SERVICE LATERAL
3-PHASE, 4-WIRE, 208Y/120 OR 480Y/277 VOLTS, 0-200 AMPERES
METERING SEQUENCE: METER-SWITCH-FUSE (See Note 3)

Customer furnishes and installs:

1. Service entrance conduit and conductors.
2. Company listed 7-terminal meter socket (see Note 1 and Sheet D-8).
3. 7th terminal with potential tap (see Note 2).
4. Service lateral conduit.
5. Metallic conduit shall be bonded to the meter socket.

Company furnishes and installs:

6. Service lateral.
7. Watthour meter (not shown).

Notes:

1. Provide 4" clearance around meter from all foreign objects.
2. If the potential tap from the neutral conductor to the 7th terminal is not provided by the manufacturer it shall be a #14 white insulated wire.
3. SW-F-M sequence is required for indoor, 208Y/120 Volt, AC network services (downtown Milwaukee).

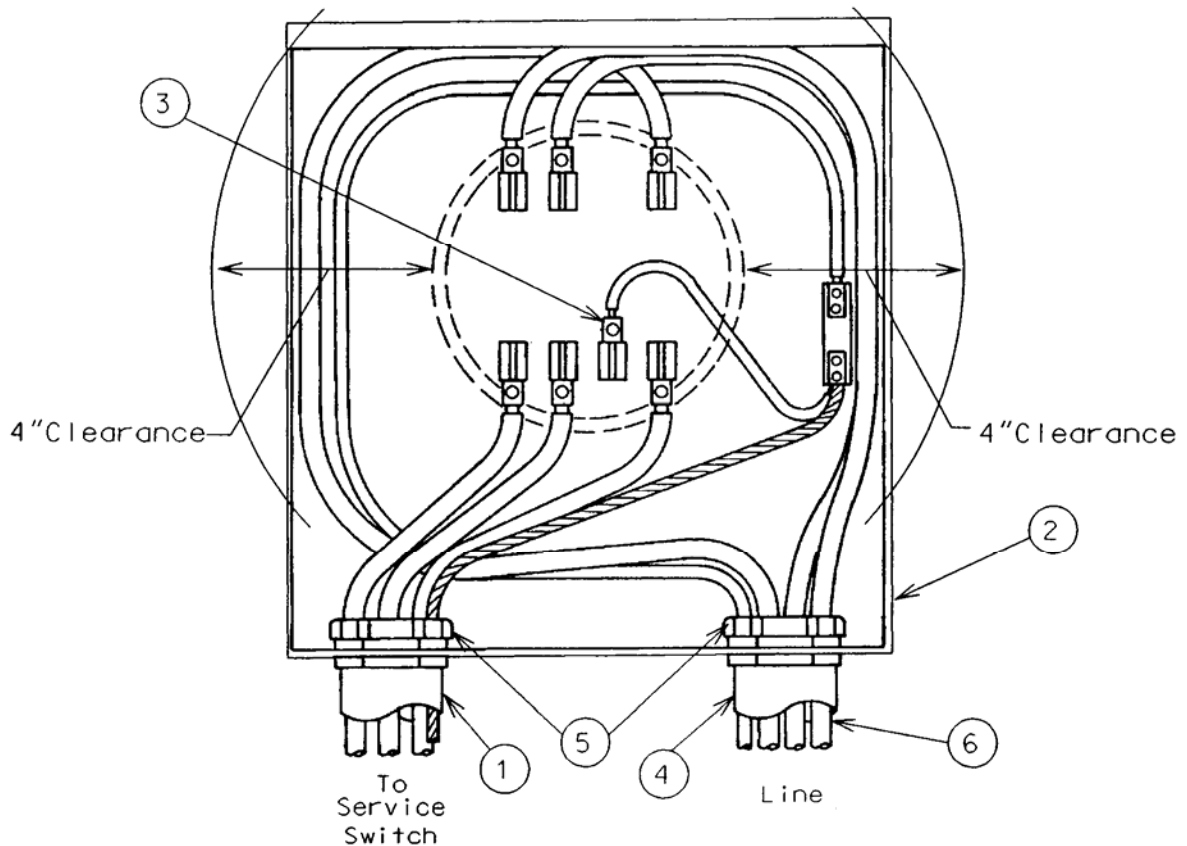

TRANSOCKET WITH OVERHEAD SERVICE ENTRANCE

1-PHASE, 3-WIRE, 120/240 VOLTS, 201-800 AMPERES

ALL 3-PHASE VOLTAGES, 201-2000 AMPERES

METERING SEQUENCE: METER-SWITCH-FUSE (See Note 3)

Obtain acceptance for 1-phase installations larger than 400 amperes from the Company.

Customer furnishes and installs:

1. Company listed transocket with transformer rated meter socket (see Note 1 and Sheets D-16 & D-18).
2. Service entrance conduit(s) and conductors.
3. Metallic conduit shall be bonded.
4. Solid bar (see Note 2).

Company furnishes and installs:

5. Current transformers.
6. Watthour meter and wiring (not shown).

Note:

1. A 6-terminal socket is required for a 1-phase, 3-wire service; an 8-terminal socket is required for a 3-phase, 3-wire service; a 13-terminal socket is required for a 3-phase, 4-wire service.
2. For 480 volt ungrounded applications the center phase bar (required) shall be removable.
3. SW-F-M sequence is required for, 208Y/120 Volt, AC network services (downtown Milwaukee area).

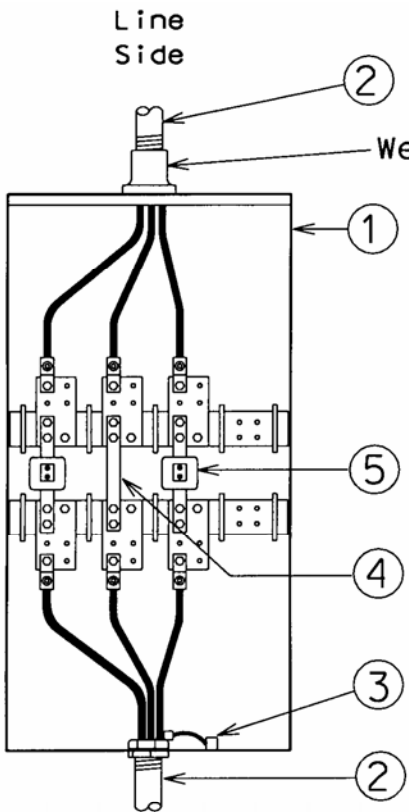

Load Side
to Main
Disconnect

1 \emptyset or 3 \emptyset , 3 Wire
Cover Removed

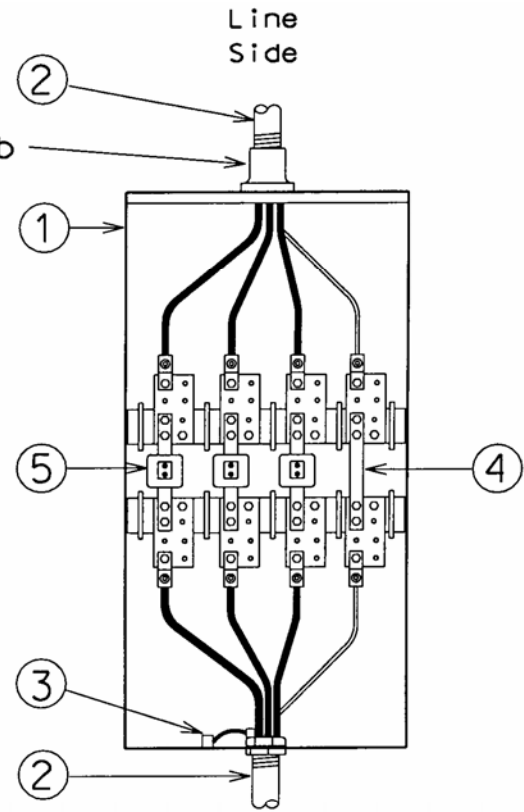

Load Side
to Main
Disconnect

3 \emptyset , 4 Wire
Cover Removed

TRANSOCKET WITH UNDERGROUND SERVICE LATERAL
1-PHASE, 3-WIRE, 120/240 VOLTS, 201-800 AMPERES
ALL 3-PHASE VOLTAGES, 201-2000 AMPERES
3-PHASE, 4-WIRE, 208Y/120 VOLTS or 480Y/277 VOLTS, 201-3000 AMPERES
METERING SEQUENCE: METER-SWITCH-FUSE (See Note 3)
Obtain acceptance for 1-phase installations larger than 400 amperes from the Company.

Customer furnishes and installs:

1. Company listed transocket with transformer rated meter socket (see Note 1 and Sheets D-17 & D-18).
2. Service lateral conduit (800 A. wireway shown).
3. Service entrance conduit and conductors.
4. Metallic conduit shall be bonded.
5. Solid bar (see Note 2).

Company furnishes and installs:

6. Service lateral and lug type terminations.
7. Current transformers.
8. Watthour meter and wiring (not shown).

Note:

1. A 6-terminal socket is required for a 1-phase, 3-wire service; an 8-terminal socket is required for a 3-phase, 3-wire service; a 13-terminal socket is required for a 3-phase, 4-wire service.
 2. For 480 volt ungrounded applications the center phase bar (required) shall be removable.
 3. SW-F-M sequence is required for, 208Y/120 Volt, AC network services (downtown Milwaukee area).
 4. This wiring gutter is for the service lateral (Item 6) only. No other conductors are to pass through it.
- The transocket shown has the wiring space on the right, units with the space on the left are also available.

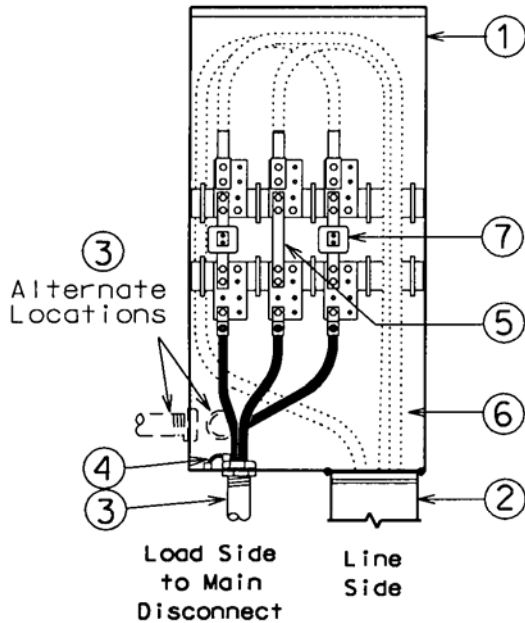

1Ø or 3Ø, 3 Wire
 Cover Removed
 (400 Ampere shown)

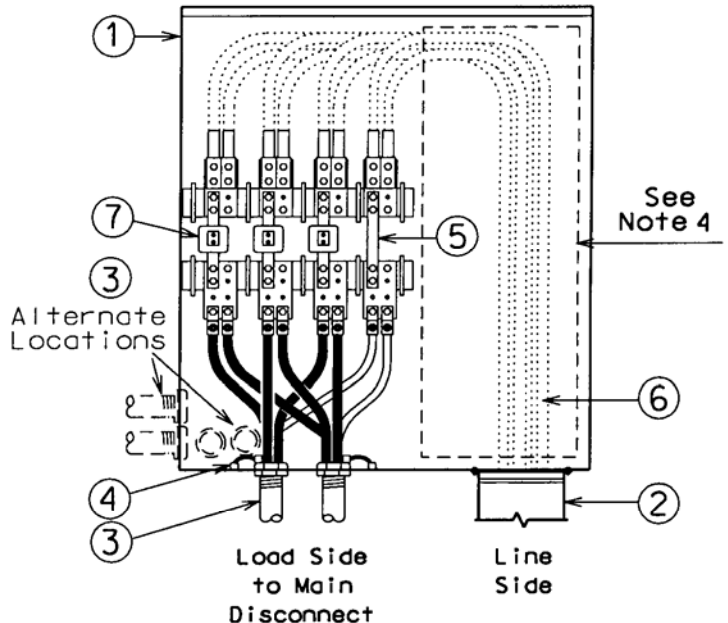

3Ø, 4 Wire
 Cover Removed
 (800 Ampere shown)

**OUTDOOR CURRENT TRANSFORMER METERING WITH
CUSTOMER DISCONNECT
1-PHASE, 3-WIRE, 120/240 VOLTS, 201-800 AMPERES
ALL 3-PHASE VOLTAGES, 201-1200 AMPERES
METERING SEQUENCE: METER-SWITCH-FUSE (See Note 3)**

Customer furnishes and installs:

1. Company listed combination metering transformer section and disconnect with transformer rated meter socket (see Note 1 and Sheet D-17).
2. Service entrance conduit and conductors, metallic conduit shall be bonded.
3. Wireway, 1600A. maximum.
4. Wiring Gutter for Service Lateral (Item 7) only (see Note 4).
5. Solid bar (see Note 2).

Company furnishes and installs:

6. Current transformers.
7. Service lateral and lug type terminations.
8. Watthour meter and wiring (not shown).

Note:

1. A 6-terminal socket is required for a 1-phase, 3-wire service; an 8-terminal socket is required for a 3-phase, 3-wire service; a 13-terminal socket is required for a 3-phase, 4-wire service.
2. For 480 volt ungrounded applications the center phase bar (required) shall be removable.
3. SW-F-M sequence is required for, 208Y/120 Volt, AC network services (downtown Milwaukee area).
4. The unit shown has the wiring space on the right, units with the space on the left are also available.

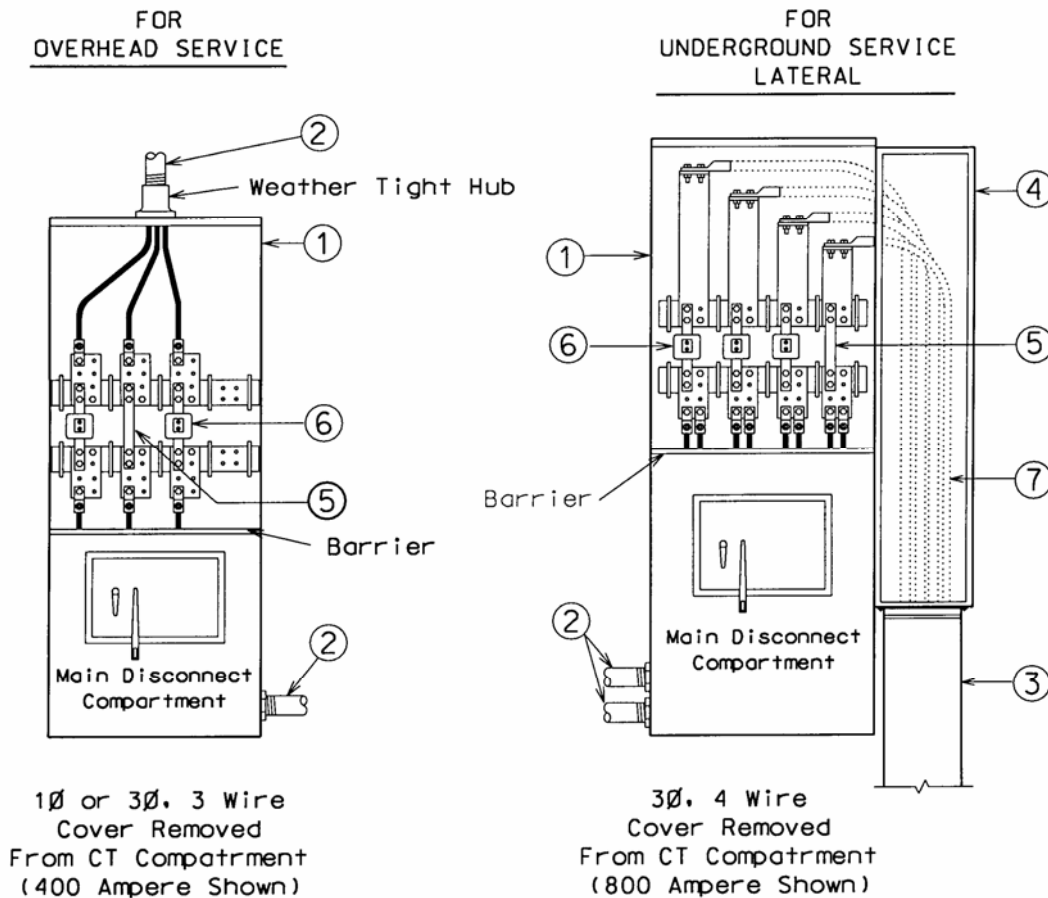

**METER STACK SOCKET BREAKER INSTALLATION
All 1-PHASE, 3-WIRE, AND ALL 3-PHASE VOLTAGES
0-200 AMPERES PER METER**

METERING SEQUENCE: METER-SWITCH-FUSE (See Note 4)

Customer furnishes and installs:

1. Company listed termination compartment, breaker/disconnect, switch/fuse combination (see Sheet D-20).
2. Company listed meter stacks (see Notes 1, 2, & 3 and Sheets D-13 thru D-16).
3. Wireway (1600 Amp. max., see Sheet D-18) for service lateral. For outdoor use only.
4. Conduit, 4"(Rigid or IMC if used outdoors) for service lateral. (See pages U-18 to U-23 for details).
5. Spacer, (see Note 1 for requirements).
6. Label identifying the individual unit served by the meter position. (See Note 5).

Company furnishes and installs:

7. Watthour meters.
8. Service Lateral.

Notes:

1. 4" of clearance around meter is required. Where the termination/switch/fuse compartment or switch handles have less than the 4" clearance a spacer is required (Item 5).
2. All panels shall be removable for inspection or wiring. Each meter socket shall be individually sealable.
3. Before ordering and installing meter stacks, verify that the stack will meet the minimum and maximum meter height requirements when installed.
4. SW-F-M is required for each meter for 208Y/120 Volt, AC network (downtown Milwaukee), multi-meter services without a main disconnect.
5. Each meter position shall be marked on the outside of the socket or by the breaker (if available) with the address of the unit served. If the marking is on the outside of the removable cover, it shall also be marked on the inside of the meter socket in a visible location. This marking shall also be placed on the corresponding distribution panel(s). The marking shall be a permanent label with 1/2" block letters and may consist of individual self-stick letters or numbers, suitable for the location so as to be considered permanent.

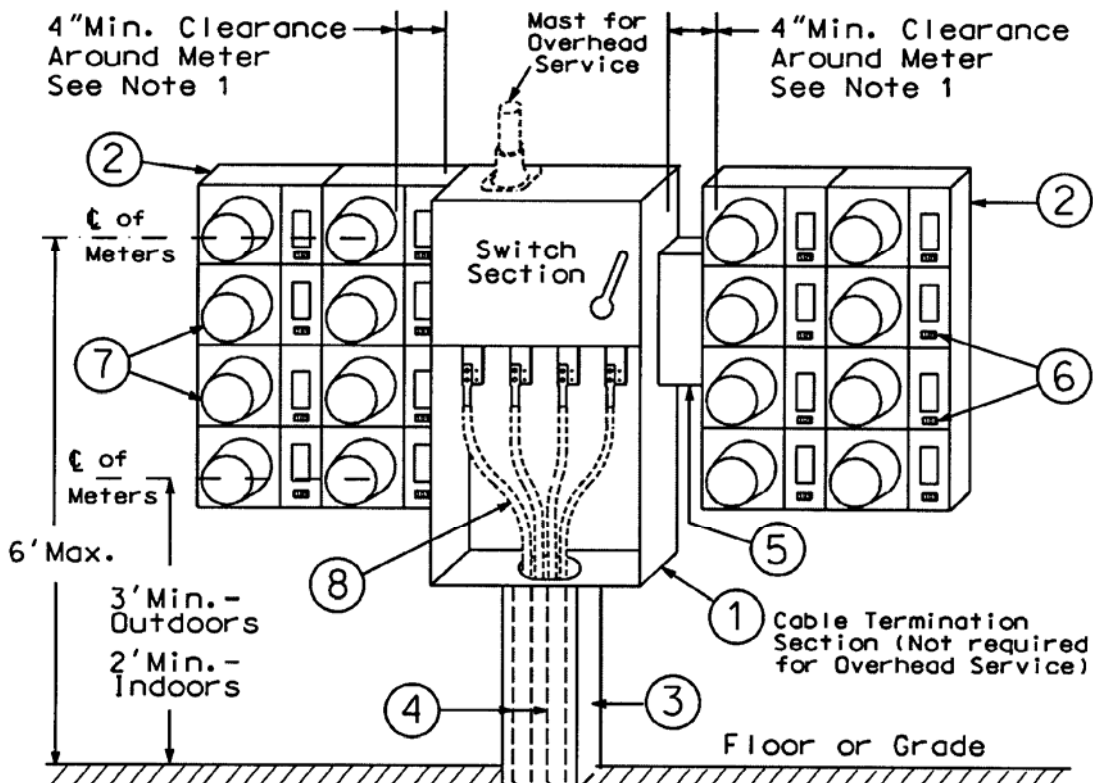

**INDOOR CURRENT TRANSFORMER METERING
IN FREE STANDING SWITCHGEAR
1-PHASE, 3-WIRE, 120/240 VOLTS, 201-800 AMPERES
ALL 3 PHASE VOLTAGES, 201-4000 AMPERES
METERING SEQUENCE: METER-SWITCH-FUSE (See Note 15)**

Customer furnishes and installs:

1. Company listed transformer rated meter socket (see Note 1 and Sheet D-18).
2. Conduit (see Note 2).
3. Current transformer (CT) compartment as part of the main switchboard (see Notes 3 to 14).
4. Main breaker compartment.
5. Distribution equipment.
6. Service entrance (see Overhead or Underground Sections for installation details).
7. Alternate location of the line and load side bus bar.
8. Alternate location for insulating barrier when alternate load bus is used.

Company furnishes and installs:

9. Meter test switch (not shown).
10. Watthour meter (not shown).
11. Meter wire from the secondary side of current transformers to meter (not shown).
12. Indoor current transformers and the necessary mounting bolts (not shown, see Note 12).

Notes:

1. Meter socket shall be installed within sight of or attached to the CT compartment with the following limitations:
 - a. Meter must be installed in a suitable location as outlined in the preceding General Requirements.
 - b. Meter conduit shall be run exposed where practicable.
 - c. Consult the Company if the distance between the CT compartment and meter location exceeds 40'.
2. 1-1/4" Galvanized rigid, galvanized intermediate or rigid nonmetallic Schedule 40 PVC conduit per NEMA Standard TC-2, to extend between the CT compartment and meter cabinet. If nonmetallic conduit is used, a #12 copper conductor or equivalent must be installed in the conduit to maintain continuity of equipment ground. This conductor must be bare or green covered with one or more yellow stripes.
3. The CT compartment shall be completely enclosed; barriers between compartments shall be rigidly supported.
4. No transition bus is allowed within the CT compartment with the bus configuration shown.
5. Front of CT compartment shall be enclosed using one of the following methods:
 - a. Double hinged door with sealable hasp and double bolt type latch (preferred).
 - b. Single hinged door with sealable hasp and double bolt type latch.
6. The following live part clearances must be maintained: 2" phase-to-phase, 1" phase-to-ground.
7. The CT bar will be drilled to conform to EEI Pub. MSJ-11.
8. For 1-phase and 3-phase services less than 1200 amperes, provide a threaded hole in neutral bar for a potential tap (Tap hole for No. 10-24 brass screw). For 3-phase services, 1201 - 4000 amperes, provide a threaded hole in the bus bars of each phase and the neutral for the potential tap as shown in the bus bar drilling detail.
9. Bus supports shall have a minimum separation of 15" and shall consist of an insulating material such as Benelex or equivalent, or porcelain insulators mounted on a steel channel.
10. Neutral bus bar must either run through or be extended back into the CT cabinet so that it is accessible for the potential tap. Working clearance between neutral bus and any live bus in the vicinity of the CT mounting must be 6" minimum. Neutral bus must not be located closer to the front of the enclosure than any live bus.
11. The compartment detail shown is for use with a 3-phase, 4-wire system. For 3-wire systems, the center phase bar is to be continuous, and the neutral bar is omitted.
12. The customer may consult the Company and make arrangements to pick up and install the CTs.
13. For services less than 1200 amperes, refer to Sheet D-18 for listed CT compartments.
14. Submit 3 drawings of the proposed CT compartment details to the local Company office for acceptance.
15. SW-F-M sequence is required for, 208Y/120 Volt, AC network services (downtown Milwaukee area).

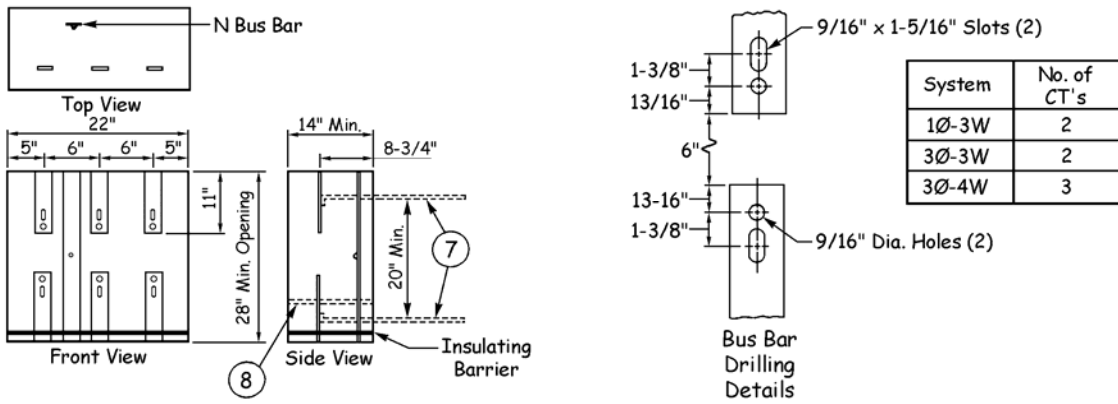
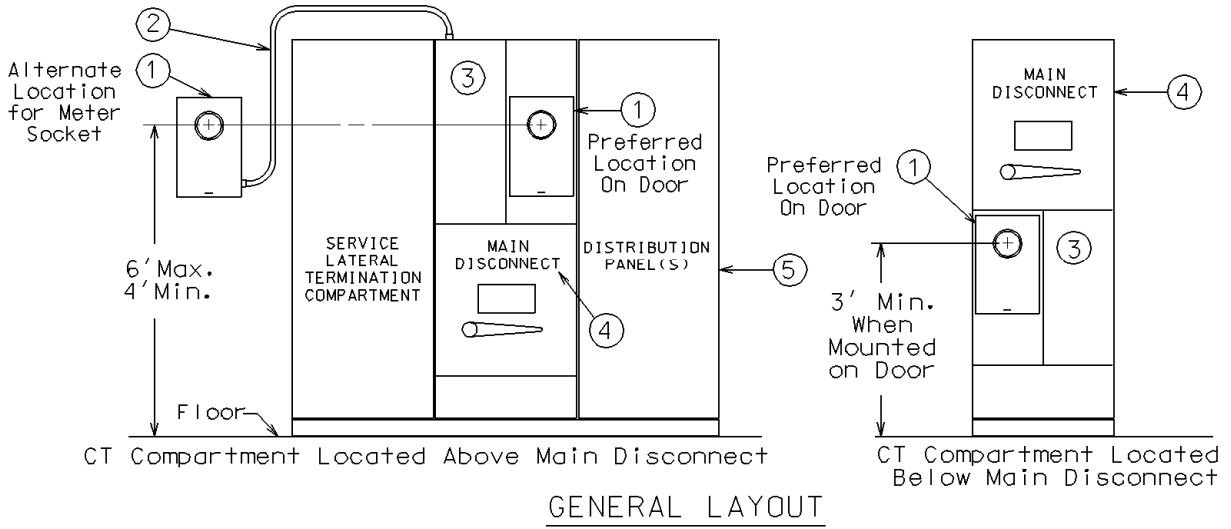

**1-PHASE, 120/240 VOLTS, 201-800 AMPERES
ALL 3-PHASE VOLTAGES, 201-1200 AMPERES**

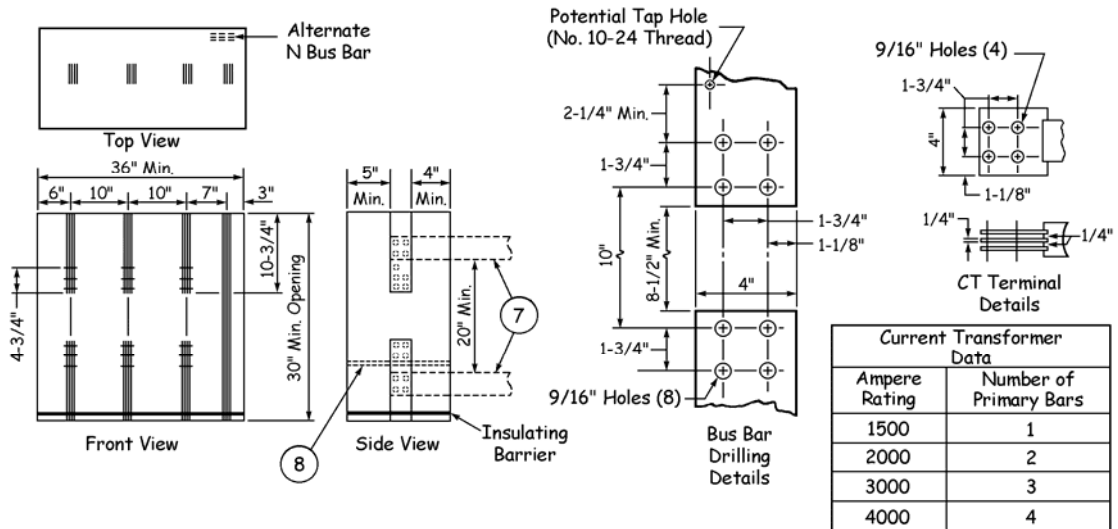

ALL 3-PHASE VOLTAGES, 1201-4000 AMPERES

INDOOR MODULAR METERING
1-PHASE, 3-WIRE, 120/240 OR 208Y/120 VOLTS, 0-200 AMPERES PER METER
ALL 3-PHASE VOLTAGES, 0-200 AMPERES PER METER

Obtain acceptance from the Company.

Customer furnishes and installs:

1. Provisions for sealing (see Note 1).
2. Sealable cover. Double covers must be equipped with handles.
3. Benelex or polyester barrier (see Note 2).
4. Main disconnect when required (see Note 3).
5. Individual tenant disconnects.
6. Load conductor wireway.
7. Modular meter units (see Notes 4, 5, 6, 7 & Sheet D-16).

Company furnishes and installs:

8. Watthour meters.

NOTES:

1. All covers which could expose unmetered bus shall have provisions for sealing.
2. All load wireways and lugs for connection of load conductors shall be separated by barriers from the meter area, and from unmetered bus.
3. This device as shown is not suitable for the direct termination of Company service conductors. See Overhead or Underground Sections of the manual for the appropriate termination methods.
4. For a 3-phase, 3-wire, 480 volt meter socket, there must be a center phase disconnecting link.
5. Provide 4" clearance around meter from all foreign objects.
6. The meter disconnect combination may consist of a preassembled module designed to be inserted into a bussted enclosure.
7. Each meter position shall be marked on the outside of the socket or by the breaker (if available) with the address of the unit served. If the marking is on the outside of the removable cover, it shall also be marked on the inside of the meter socket in a visible location. This marking shall also be placed on the corresponding distribution panel(s). The marking shall be a permanent label with 1/2" block letters and may consist of individual self-stick letters or numbers, suitable for the location so as to be considered permanent.

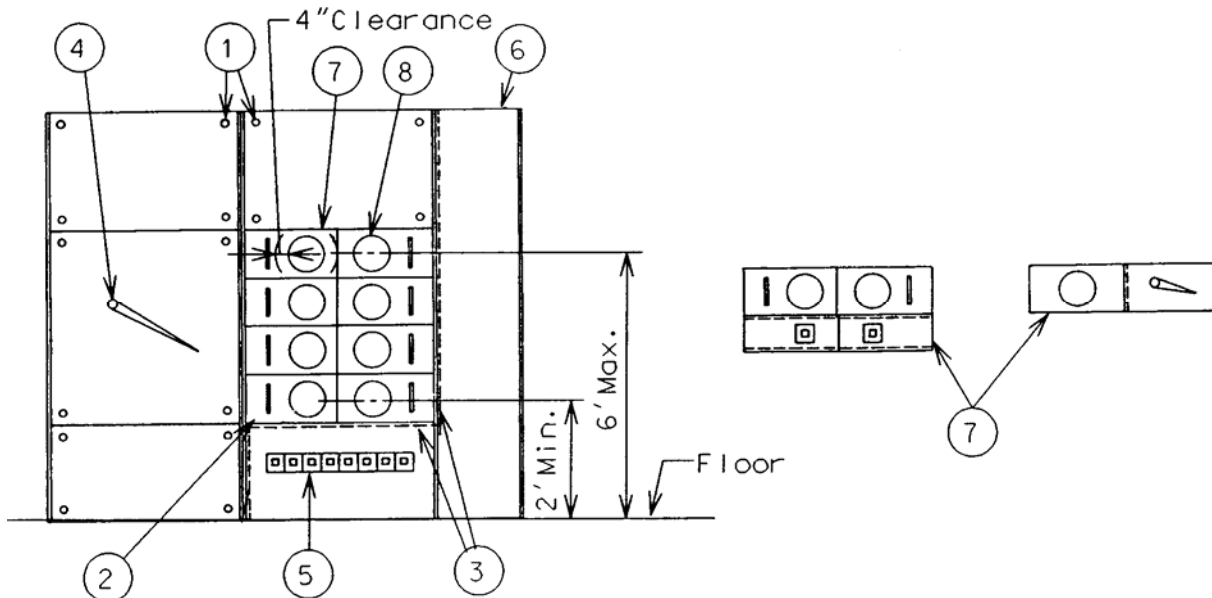

FULLY ASSEMBLED METERING SWITCHBOARD