



Consulting
Engineers and
Scientists

Regulation Compliance Report Run-on and Run-off Control Plan

Caledonia Ash Landfill
Caledonia, Wisconsin

Submitted to:

WEC Energy Group – Business Services
333 W. Everett Street, A231
Milwaukee, Wisconsin 53203

Submitted by:

GEI Consultants, Inc.
3159 Voyager Drive
Green Bay, Wisconsin 54313
920.455.8200

October 2021, Revision 1

Project 1610530

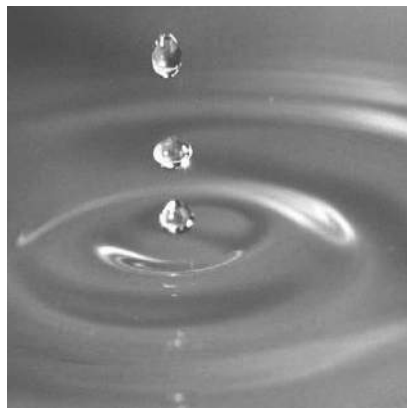

John M. Trast, P.E., D.G.E.
Vice President

William S. Reybrock, P.E.
Project Professional

Table of Contents

| | | |
|-----------|--|----------|
| 1. | Introduction | 1 |
| 2. | Storm and Stormwater Volume Determination | 2 |
| 3. | Run-on Control System | 3 |
| 4. | Run-off Control System | 4 |
| 5. | Conclusion and Certification | 6 |
| 6. | References | 7 |

Tables

2-1 Summary of Rainfall Precipitation and Run-off Volume Data

Appendices

Appendix A Drawings

Appendix B NOAA 14, Vol. 8 Rainfall Analysis and Run-off Volume

Appendix C Stormwater Run-on Calculations

Appendix D Stormwater Run-off Calculations

Revision Schedule

Revision 0 October 2016

Revision 1 October 2021: This plan was updated in accordance with § 257.81(c)(4) which required the owner or operator of the CCR unit to prepare periodic run-on and run-off control system plans every five years. Updated the existing site conditions and engineering calculations.

WSR:cah

\\grb-pzcc-1\GRB\Projects\WEC Energy Group\1610530_We Energies Caledonia LF Engineering Assistance\In_Progress\257.81Runon and runoff controls\2021\R1610530_Caledonia Runon Runoff Mgmt Plan_v1_Oct_2021_FINAL.docx

1. Introduction

WEC Energy Group (WEC) owns and operates a solid waste disposal facility on the Oak Creek Site in the NE 1/4 of Section 1, Township 4 North, Range 22 East, in the Village of Caledonia, Racine County, Wisconsin. The WEC Caledonia Ash Landfill is regulated as an industrial waste landfill by the Wisconsin Department of Natural Resources (WDNR) under the provisions of Chapter 289 Wisconsin State Statutes, and all applicable requirements of Chapters NR 500 of the Wisconsin Administrative Code. The design, construction, operation, closure, and post-closure care requirements are specified in the WDNR conditionally approved Plan of Operations, License No. 03232, FID No. 252108450. As currently constructed, the landfill has 24.2 acres open, 34.9 acres of base liner system (Cells 1, 2, 3, 4, 6, 8, and 10) is constructed, and 10.7 acres of perimeter slopes (Cells 1, 2, 3, 4, and 6) have received final cover.

In addition to the state regulations, the landfill is also required to comply with 40 CFR Part 257 Subpart D – *Standards for Disposal of Coal Combustion Residuals in Landfills and Surface Impoundments*. Cells 1, 2, 3, 4, 6, 8, and 10 were constructed prior to October 14, 2015, and are defined as an existing CCR landfill in accordance with § 257.53. Future landfill cells are permitted by the WDNR in the conditionally approved Plan of Operation and defined as lateral expansions under § 257.53 when developed.

This report fulfills the requirements of § 257.81 - *Run-on and run-off controls for CCR landfills* for the Caledonia Ash Landfill, which specifies that the owner or operator must complete the assessments required by this section every five years. In accordance with 257.81(c)(1) this report describes how the run-on and run-off control systems have been designed and constructed to meet the applicable requirements and supported by appropriate engineering calculations.

This run-off and run-on system control plan includes the following sections:

- Section 1 – Introduction
- Section 2 – Storm and Stormwater Volume Determination
- Section 3 – Run-on Control System
- Section 4 – Run-off Control System
- Section 5 – Conclusion and Certification
- Section 6 – References

2. Storm and Stormwater Volume Determination

§ 257.81 *Run-on and run-off controls for CCR landfills* requires that the owner or operator of an existing or new CCR landfill or any lateral expansion of a CCR landfill must design, construct, operate, and maintain a run-on control system to prevent flow onto the active portion of the CCR unit during the peak discharge from a 24-hour, 25-year storm; and a run-off control system from the active portion of the CCR unit to collect and control at least the water volume resulting from a 24-hour, 25-year storm.

The active filling area of the landfill is approximately 24.2 acres and approximately 10.7 acres of the landfill has final cover. All precipitation that falls into the active filling area of the permitted limits of waste is contained within the landfill and handled as leachate. Any precipitation that falls outside the limits of waste is directed away from the active landfill. Any precipitation that falls on the portion with final cover is directed off the landfill as noncontact water. Drawing C-1 – Caledonia Ash Landfill shows existing landfill grades as of December 29, 2017, and shows intermediate filling plan elevations for the Caledonia Ash Landfill. The drawing is located in Appendix A – Drawings.

The rainfall depth estimate for a 24-hour, 25-year storm for the Caledonia Ash Landfill was determined following the procedures outlined in Precipitation-Frequency Atlas of the United States, Atlas 14, Volume 8, Version 2: Wisconsin. For the Caledonia Ash Landfill a 24-hour, 25-year storm will result in 4.48 inches of rainfall. Calculations for determining the 24-hour, 25-year storm event are included in Appendix B: NOAA 14, Vol. 8 Rainfall Analysis and Run-off Volume.

Table 2-1 summarizes the storm recurrence interval, rainfall depth, lined area of the CCR landfill, and minimum stormwater volume required to be managed within Landfill.

Table 2-1 Summary of Rainfall Precipitation and Run-off Volume Data

| Storm Recurrence Interval | Rainfall Depth (inches) | Active Landfill Lined Area (acres) | Run-off Volume (acre-ft) |
|---------------------------|-------------------------|------------------------------------|--------------------------|
| 24-hour, 25-year | 4.48 | 24.24 | 9.05 |

3. Run-on Control System

§ 257.81 (a)(1) requires a run-on control system to prevent flow onto the active portions of the CCR unit during the peak discharge from a 24-hour, 25-year storm. The federal rule defines “Run-on” as *“any rainwater, leachate, or other liquid that drains over land onto any part of a CCR landfill.”*

In order to control stormwater and prevent run-on to the landfill, perimeter berms have been established around the landfill facility. These perimeter berms contain all run-off within the landfill. On the east and west sides of the landfill, stormwater ditches between the access road and the landfill perimeter berm conveys stormwater southward. On the east side of the landfill the stormwater is routed to the stormwater detention basin immediately southeast of the landfill. On the west side of the landfill the stormwater is routed south, through a culvert running under the site screening berm, and then east to the stormwater detention basin immediately southeast of the landfill. In general, all stormwater drainage at the site is directed away from the active landfill and to the stormwater detention basin.

Along the north side of the landfill, an intercell berm was constructed to prevent run-on from entering the landfill and to prevent run-off from leaving the landfill. A perimeter ditch along the north edge of the intercell berm intercepts and directs stormwater run-on to the east away from the active area and connects to the east stormwater ditch described above. Run-on controls are shown on Drawing C-1 in Appendix A.

Stormwater modeling was completed to confirm that the current run-on control system on the north side of the landfill is sufficiently sized to manage a 24-hour, 25-year precipitation event. HydroCAD 10.0 was used to model the potential for stormwater run-on into the landfill from the north. The stormwater run-on calculations are included in Appendix C – Stormwater Run-on Calculations. Based on the stormwater model, the current run-on control system on the north side of the Caledonia landfill will be able to handle the 24-hour, 25-year precipitation event without allowing any non-contact water to enter the limits of waste. The estimated peak water level in the channel is 1.2 feet. The conveyance channel north of the intercell berm is adequately sized to prevent run-on to Cell 1 associated with the 24-hour, 25-year precipitation event.

Based on a review of current topography and stormwater calculations, the Caledonia Ash Landfill has an acceptable run-on control system that follows current engineering standards and is in compliance with § 257.81(a)(1).

4. Run-off Control System

§ 257.81 (a)(2) requires a run-off control system from the active portion of the CCR unit to collect and control at least the water volume resulting from a 24-hour, 25-year storm. The federal rule defines “Run-off” as “*any rainwater, leachate, or other liquid that drains overland from any part of a CCR landfill.*”

During the operation and filling of the Caledonia Ash Landfill precipitation within the active landfill is handled as contact stormwater and treated as leachate in accordance with § 257.3-3. The contact stormwater is directed to the temporary stormwater ditches on the inside of the landfill and routed to temporary infiltrations area in Cells 8 and 10, where it is allowed to infiltrate into the leachate collection system. The water is managed as leachate in accordance with the landfill Plan of Operations.

A stormwater run-off model was completed to confirm that the current run-off control system for the operation of the Caledonia Ash Landfill can adequately manage a 24-hour, 25-year precipitation event. Stormwater flow was modeled using HydroCAD 10.0 to model the operational filling condition as shown on Drawing C-1. Based on the landfill development plan the condition that will have the steepest and longest slopes directing stormwater to the temporary containment ditches will occur prior to the installation of the final cover over Cells 2 and 3. This plan will require updating after final cover is installed over Cells 2 and 3. The stormwater run-off calculations for the proposed filling condition are included in Appendix C: Stormwater Run-off Calculations.

For modeling purposes contact stormwater on the proposed intermediate filling condition are divided into five (5) sub-catchments: southwest side, north slope, southeast side, west side slope, and stormwater surge area. Stormwater for the sub-catchments is routed as sheet flow and shallow concentrated flow either directly into an intercell stormwater surge area on the perimeter of Cells 8 and 10 of the landfill, or as sheet flow until the water is intercepted by a temporary stormwater channel.

In general, the intermediate cover perimeter channels are a minimum of 3 feet deep and have a 2H:1V interior and 2H:1V or 3H:1V exterior slopes depending on the location within the landfill. In Cells 8 and 10, the exterior slope is 3H:1V and is the top of the granular drainage layer of the leachate collection system. At other locations where the ditch is simply constructed in the CCR the slope is 2H:1V. Contact stormwater from the perimeter channels is conveyed to the intercell stormwater surge area. From the intercell stormwater surge area the water infiltrates through the granular drainage layer into the leachate collection system and is treated as leachate. Although contact stormwater can and will infiltrate once it reaches the perimeter ditch, for the stormwater modeling and sizing purposes, we have conservatively assumed a 2H:1V ditch that does not allow infiltration. During installation of the final cover, the temporary stormwater containment ditches will be filled with soil or CCR prior to placement of the final cover system. Along the access road a cattle bridge or cattle guard is

installed to function at cell entrance points as a hydraulic break and prevent stormwater from running down the road and escaping the site. The cattle bridge also allows for the continuation of the perimeter ditch.

Based on the analysis, the run-off control system for the Caledonia Ash Landfill is able to contain, manage, and control the run-off from a 24-hour, 25-year precipitation event without allowing any contact water to escape the permitted limits of waste. The intercell stormwater surge area has a minimum crest elevation of approximately El. 700.0 feet, and the estimated water level associated with the 24-hour, 25-year storm is El. 695.6 feet. Both the temporary stormwater containment ditches and the stormwater surge area are designed to contain, manage, and control the run-off from the landfill associated with the 24-hour, 25-year storm event.

5. Conclusion and Certification

The Caledonia Ash Landfill is regulated under 40 CFR Part 257 Subpart D as an existing CCR landfill. The rule specifies that existing CCR landfills must develop plans to meet certain meet operating criteria designated by October 17, 2016, and that the owner or operator must also conduct and complete the assessments required by this section every five (5) years maximum based on the completion date of this plan. This report is the 5-year update to the original plan. The revised plan must be placed in the facility's operating record as required by §257.105(g). The owner or operator of the CCR unit must comply with the recordkeeping requirements specified in § 257.105(g), the notification requirements specified in § 257.106(g), and the internet requirements specified in § 257.107(g).

This report documents that the Caledonia Ash Landfill has an established run-on and run-off control system design capable of controlling the peak discharge from a 24-hour, 25-year storm event and complies with § 257.81 *Run-on and run-off controls for CCR landfills*. All leachate that is collected at the Caledonia Ash Landfill is either recycled for use as a dust control agent in the active landfill or hauled to the wastewater treatment facility in accordance with the Plan of Operations; thus, it complies with § 257.3-3.

The plan was completed under the direction of John M. Trast, P.E., D.GE. I am a licensed professional engineer in the State of Wisconsin in accordance with the requirements of ch. A-E 4, Wisconsin Administrative Code; that this document has been prepared in accordance with the Rules of Professional Conduct in ch. A-E 8, Wisconsin Administrative Code; and that, to the best of my knowledge, all information contained in this document is correct and the document was prepared in compliance with all applicable requirements in 40 CFR Part 257 Subpart D.



6. References

Perica, S., D. Martin, S. Pavlovic, I. Roy, M. St. Laurent, C. Trypaluk, D. Unruh, M. Yekta, G. Bonnin (2013). NOAA Atlas 14 Volume 8 Version 2.0, *Precipitation-Frequency Atlas of the United States, Midwestern States*. National Oceanic and Atmospheric Administration, National Weather Service, Silver Spring, Maryland.

US Department of Commerce. National Oceanic and Atmospheric Administration, National Weather Service. (2016). Precipitation Frequency Data Server (PFDS).
<http://hdsc.nws.noaa.gov/hdsc/pdfs/>.

Appendix A

Drawings

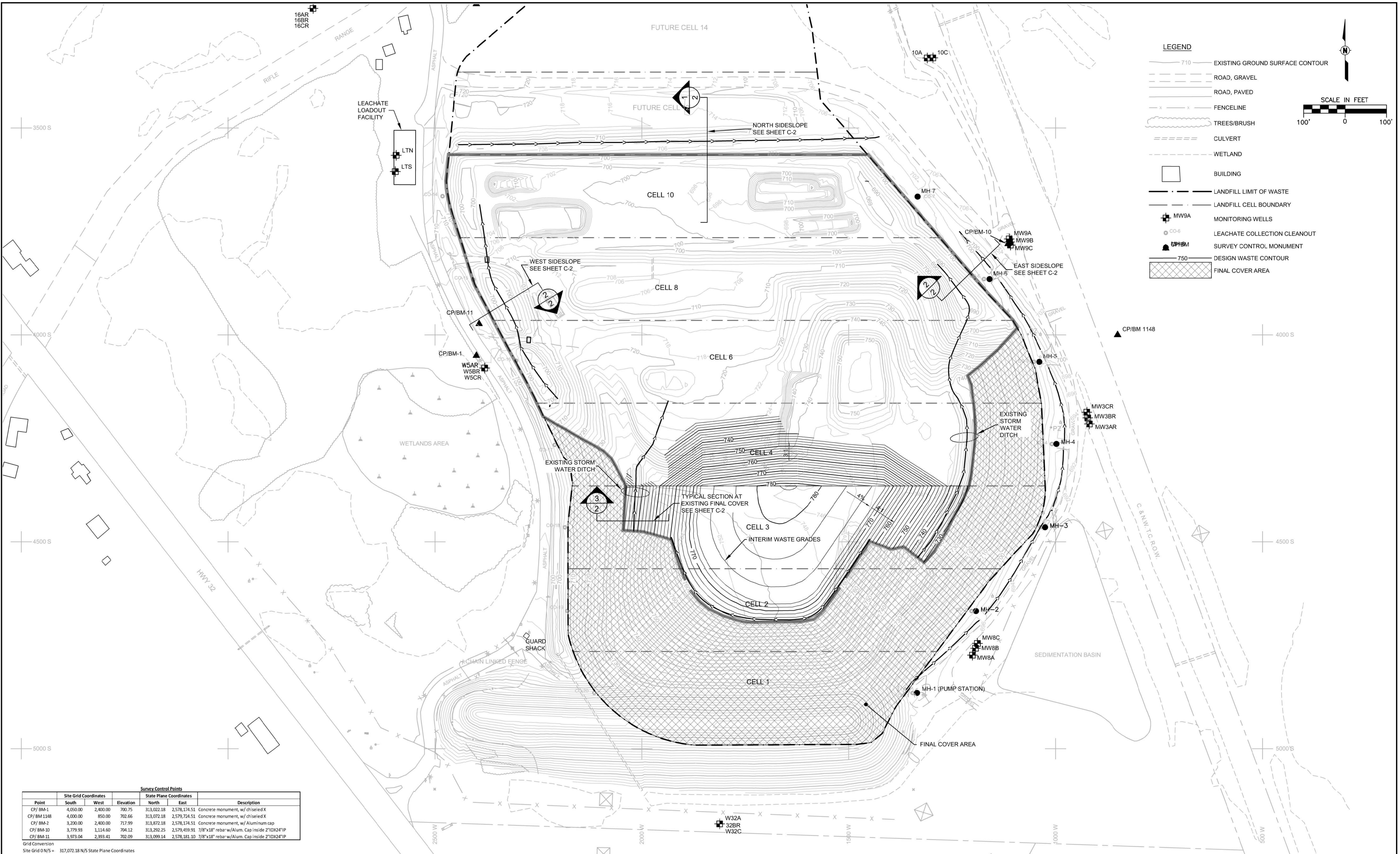

LEGEND

- 710 — EXISTING GROUND SURFACE CONTOUR
- ROAD, GRAVEL
- ROAD, PAVED
- x-x-x- FENCELINE
- TREES/BRUSH
- CULVERT
- WETLAND
- BUILDING
- LANDFILL LIMIT OF WASTE
- LANDFILL CELL BOUNDARY
- ⊕ MW9A MONITORING WELLS
- CO-6 LEACHATE COLLECTION CLEANOUT
- ▲ CP/BM SURVEY CONTROL MONUMENT
- 750 DESIGN WASTE CONTOUR
- ▨ FINAL COVER AREA

Survey Control Points

| Point | Site Grid Coordinates | | | State Plane Coordinates | | | Description |
|-------------|-----------------------|----------|-----------|-------------------------|--------------|--|---|
| | South | West | Elevation | North | East | | |
| CP/ BM-1 | 4,050.00 | 2,400.00 | 700.75 | 313,022.18 | 2,578,174.51 | | Concrete monument, w/ chiseled X |
| CP/ BM 1148 | 4,000.00 | 850.00 | 702.66 | 313,072.18 | 2,579,724.51 | | Concrete monument, w/ chiseled X |
| CP/ BM-2 | 3,200.00 | 2,400.00 | 717.99 | 313,872.18 | 2,578,174.51 | | Concrete monument, w/ Aluminum cap |
| CP/ BM-10 | 3,779.98 | 1,114.60 | 704.12 | 313,292.25 | 2,579,459.91 | | 7/8"x18" rebar w/ Alum. Cap inside 2"10X24"IP |
| CP/ BM-11 | 3,973.04 | 2,393.41 | 702.09 | 313,099.14 | 2,578,181.10 | | 7/8"x18" rebar w/ Alum. Cap inside 2"10X24"IP |

Grid Conversion
 Site Grid N/S = 317,072.18 N/S State Plane Coordinates
 Site Grid E/W = 2,580,574.51 E/W State Plane Coordinates

- NOTES:**
- EXISTING CONTOURS FROM 1983 WPCO SURVEY AND RACINE COUNTY TOPOGRAPHIC MAP. CONTOURS WITHIN THE CELL 2 PARTIAL CLOSURE CONSTRUCTION AREA ARE TOP OF FINAL COVER GRADES AND WERE SURVEYED 12/29/2017 BY EDGERTON.
 - HORIZONTAL GRID IS LOCAL GRID ESTABLISHED BY OTHERS. ELEVATIONS ARE REFERENCED TO MEAN SEA LEVEL.

Attention:

| | | | |
|-----|------|----------------|-----|
| 0 | X | X | X |
| NO. | DATE | ISSUE/REVISION | APP |

Designed: JXT
 Checked: JXT
 Drawn: JLC
 Submittal Date: 7/19/2021



WE ENERGIES
 333 WEST EVERETT STREET, A231
 MILWAUKEE, WISCONSIN 53203
 GEI Project 1610530

| | |
|---|-----------------|
| REGULATION COMPLIANCE REPORT RUN-ON AND RUN-OFF CONTROL PLAN | DWG. NO. C-1 |
| CALEDONIA ASH LANDFILL | SHEET NO. 1 |

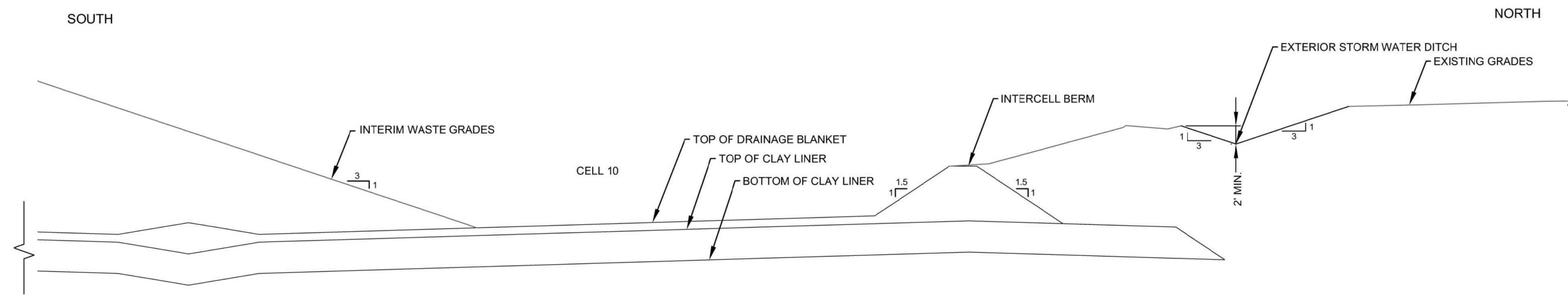

1 NORTH SIDESLOPE DETAIL
2 SCALE: 1"=10'

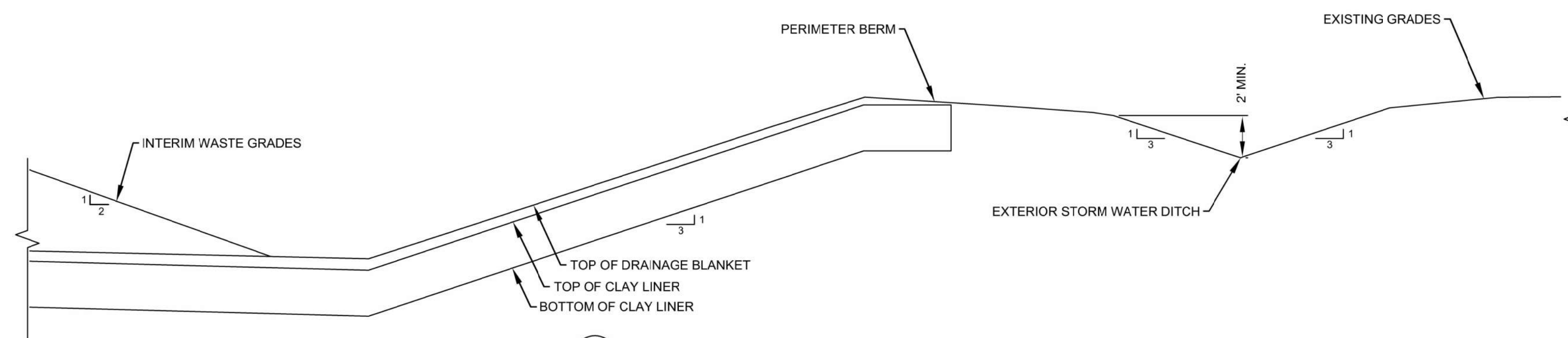

2 EAST & WEST SIDESLOPE DETAIL
2 SCALE: 1"=10'

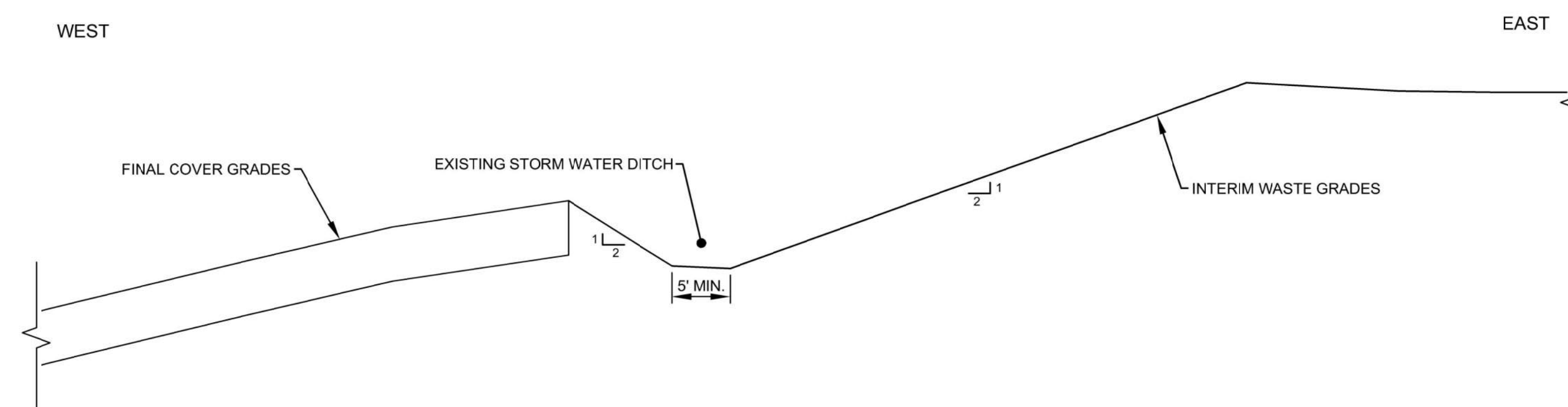

3 TYPICAL SECTION AT EXISTING FINAL COVER DETAIL
2 SCALE: 1"=10'

| Attention: | | | |
|------------|------|----------------|-----|
| NO. | DATE | ISSUE/REVISION | APP |
| 0 | X | X | X |

0 1"
If this scale bar does not measure 1" then drawing is not original scale.

Designed: JXT
Checked: JXT
Drawn: JLC
Submittal Date: 7/19/2021



WE ENERGIES
333 WEST EVERETT STREET, A231
MILWAUKEE, WISCONSIN 53203
GEI Project 1610530

REGULATION COMPLIANCE REPORT
RUN-ON AND RUN-OFF CONTROL PLAN
CALEDONIA ASH LANDFILL
DETAILS

DWG. NO.
C-2
SHEET NO.
2

Appendix B

NOAA 14, Vol. 8 Rainfall Analysis and Run-off Volume

| | | | | | | |
|---|--|--|-------------|--------------|-------------|--------------|
|  | Client | WEC Energy Group | | | Page | 1 of 4 |
| | Project | Caledonia LF Run-on and Run-off Control Plan | | | Rev. | 0 |
| | By | W. Reybrock | Chk. | A. Schwoerer | App. | A. Schwoerer |
| | Date | 10/03/2016 | Date | 8/30/21 | Date | 8/30/21 |
| GEI Project No. | 1610530 | Document No. | N/A | | | |
| Subject | NOAA 14, Vol. 8 Rainfall Analysis and Run-off Volume | | | | | |

Purpose:

The purpose of this calculation is to estimate the 24-hour, 25-year precipitation event at Caledonia landfill. The 24-hour, 25-year precipitation event is required for the run-on and run-off control system plan for the landfill.

Procedure:

The rainfall depth estimation follows the procedures outlined in Precipitation-Frequency (PF) Atlas of the United States (Atlas 14, Volume 8, Version 2: Wisconsin).

As instructed in Atlas 14, the user is referred to the NOAA Precipitation Frequency Data Server (PFDS) <http://hdsc.nws.noaa.gov/hdsc/pfds/index.html>. The approximate center of the landfill was input into the PFDS and the PF estimates were returned.

Landfill Centroid Coordinates

42°50'14.64"N 42.8374°

87°50'29.40"W -87.8415°

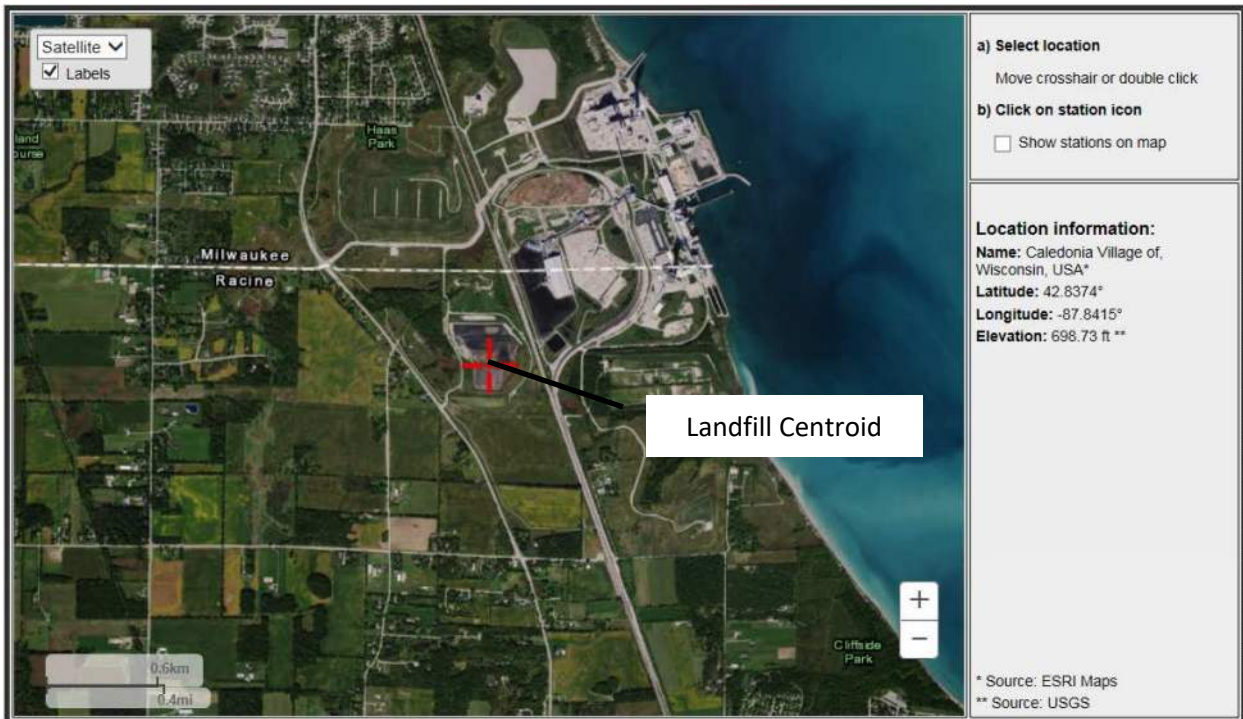



| | | | | | |
|----------------|--|-------------|--------------|-------------|--------------|
| Client | WEC Energy Group | | | Page | 2 of 4 |
| Project | Caledonia LF Run-on and Run-off Control Plan | | | Rev. | 0 |
| By | W. Reybrock | Chk. | A. Schwoerer | App. | A. Schwoerer |
| Date | 10/03/2016 | Date | 8/30/21 | Date | 8/30/21 |

| | | | |
|------------------------|--|---------------------|-----|
| GEI Project No. | 1610530 | Document No. | N/A |
| Subject | NOAA 14, Vol. 8 Rainfall Analysis and Run-off Volume | | |

Tabular Output from the PFDS:

| PDS-based precipitation frequency estimates with 90% confidence intervals (in inches) ¹ | | | | | | | | | | |
|--|-------------------------------------|------------------------|------------------------|------------------------|------------------------|------------------------|-----------------------|-----------------------|----------------------|----------------------|
| Duration | Average recurrence interval (years) | | | | | | | | | |
| | 1 | 2 | 5 | 10 | 25 | 50 | 100 | 200 | 500 | 1000 |
| 5-min | 0.326 (0.278-0.393) | 0.387 (0.330-0.467) | 0.488 (0.414-0.588) | 0.571 (0.482-0.691) | 0.685 (0.560-0.847) | 0.774 (0.619-0.965) | 0.863 (0.668-1.09) | 0.953 (0.709-1.23) | 1.07 (0.770-1.41) | 1.16 (0.815-1.55) |
| 10-min | 0.478 (0.407-0.575) | 0.567 (0.483-0.693) | 0.714 (0.606-0.861) | 0.836 (0.706-1.01) | 1.00 (0.820-1.24) | 1.13 (0.906-1.41) | 1.26 (0.978-1.60) | 1.40 (1.04-1.80) | 1.57 (1.13-2.07) | 1.70 (1.19-2.27) |
| 15-min | 0.583 (0.497-0.701) | 0.692 (0.589-0.833) | 0.871 (0.739-1.05) | 1.02 (0.860-1.23) | 1.22 (1.00-1.51) | 1.38 (1.11-1.72) | 1.54 (1.19-1.95) | 1.70 (1.27-2.20) | 1.91 (1.37-2.52) | 2.08 (1.46-2.76) |
| 30-min | 0.819 (0.698-0.985) | 0.976 (0.831-1.18) | 1.23 (1.05-1.49) | 1.45 (1.22-1.75) | 1.74 (1.42-2.15) | 1.96 (1.57-2.45) | 2.19 (1.69-2.77) | 2.41 (1.80-3.11) | 2.71 (1.95-3.56) | 2.94 (2.06-3.91) |
| 60-min | 1.05 (0.890-1.26) | 1.26 (1.07-1.52) | 1.62 (1.37-1.95) | 1.92 (1.62-2.32) | 2.34 (1.91-2.90) | 2.67 (2.13-3.33) | 3.00 (2.32-3.81) | 3.34 (2.49-4.32) | 3.80 (2.73-5.00) | 4.15 (2.91-5.52) |
| 2-hr | 1.27 (1.09-1.51) | 1.55 (1.33-1.84) | 2.00 (1.71-2.39) | 2.39 (2.04-2.86) | 2.94 (2.43-3.60) | 3.37 (2.72-4.17) | 3.81 (2.98-4.79) | 4.26 (3.21-5.46) | 4.88 (3.55-6.37) | 5.36 (3.80-7.06) |
| 3-hr | 1.41 (1.22-1.67) | 1.71 (1.48-2.03) | 2.23 (1.92-2.64) | 2.67 (2.29-3.18) | 3.31 (2.76-4.05) | 3.82 (3.11-4.71) | 4.35 (3.43-5.45) | 4.90 (3.72-6.25) | 5.66 (4.14-7.36) | 6.25 (4.46-8.19) |
| 6-hr | 1.69 (1.48-1.98) | 2.01 (1.75-2.35) | 2.57 (2.23-3.01) | 3.06 (2.65-3.60) | 3.80 (3.21-4.62) | 4.40 (3.63-5.39) | 5.05 (4.03-6.28) | 5.73 (4.41-7.26) | 6.69 (4.97-8.64) | 7.46 (5.39-9.69) |
| 12-hr | 2.04 (1.79-2.35) | 2.32 (2.04-2.69) | 2.85 (2.50-3.30) | 3.33 (2.91-3.87) | 4.08 (3.49-4.93) | 4.71 (3.94-5.72) | 5.40 (4.37-6.67) | 6.15 (4.79-7.73) | 7.22 (5.43-9.25) | 8.10 (5.91-10.4) |
| 24-hr | 2.36 (2.10-2.70) | 2.66 (2.36-3.04) | 3.20 (2.84-3.67) | 3.71 (3.27-4.26) | 4.48 (3.88-5.35) | 5.14 (4.34-6.18) | 5.86 (4.79-7.16) | 6.64 (5.23-8.26) | 7.76 (5.90-9.84) | 8.67 (6.40-11.0) |
| 2-day | 2.64 (2.37-2.98) | 3.04 (2.72-3.43) | 3.73 (3.33-4.21) | 4.33 (3.85-4.92) | 5.23 (4.54-6.13) | 5.96 (5.06-7.04) | 6.73 (5.55-8.10) | 7.56 (6.00-9.26) | 8.71 (6.68-10.9) | 9.63 (7.19-12.1) |
| 3-day | 2.89 (2.61-3.24) | 3.31 (2.98-3.71) | 4.04 (3.63-4.53) | 4.67 (4.18-5.27) | 5.61 (4.90-6.52) | 6.37 (5.44-7.47) | 7.17 (5.94-8.56) | 8.02 (6.41-9.77) | 9.21 (7.11-11.4) | 10.2 (7.64-12.7) |
| 4-day | 3.11 (2.82-3.47) | 3.54 (3.21-3.95) | 4.29 (3.87-4.79) | 4.94 (4.43-5.54) | 5.89 (5.17-6.82) | 6.68 (5.73-7.79) | 7.50 (6.24-8.90) | 8.37 (6.72-10.1) | 9.58 (7.43-11.8) | 10.5 (7.98-13.1) |
| 7-day | 3.66 (3.34-4.04) | 4.14 (3.78-4.57) | 4.96 (4.51-5.49) | 5.67 (5.13-6.29) | 6.70 (5.92-7.66) | 7.53 (6.51-8.69) | 8.39 (7.05-9.87) | 9.31 (7.54-11.2) | 10.6 (8.27-12.9) | 11.6 (8.83-14.3) |
| 10-day | 4.16 (3.82-4.57) | 4.68 (4.29-5.14) | 5.56 (5.09-6.12) | 6.32 (5.75-6.98) | 7.40 (6.57-8.39) | 8.27 (7.18-9.47) | 9.16 (7.73-10.7) | 10.1 (8.22-12.0) | 11.4 (8.95-13.8) | 12.4 (9.51-15.2) |
| 20-day | 5.69 (5.27-6.16) | 6.32 (5.85-6.85) | 7.35 (6.78-7.98) | 8.21 (7.54-8.95) | 9.41 (8.41-10.5) | 10.3 (9.06-11.7) | 11.3 (9.60-13.0) | 12.2 (10.1-14.4) | 13.5 (10.7-16.2) | 14.5 (11.3-17.6) |
| 30-day | 7.02 (6.55-7.55) | 7.77 (7.24-8.37) | 8.98 (8.33-9.68) | 9.95 (9.20-10.8) | 11.3 (10.1-12.4) | 12.3 (10.8-13.7) | 13.2 (11.3-15.0) | 14.2 (11.7-16.5) | 15.4 (12.3-18.3) | 16.3 (12.8-19.7) |
| 45-day | 8.76 (8.22-9.36) | 9.72 (9.10-10.4) | 11.2 (10.5-12.0) | 12.4 (11.5-13.3) | 13.9 (12.5-15.1) | 15.0 (13.2-16.5) | 16.0 (13.7-18.0) | 16.9 (14.1-19.5) | 18.1 (14.6-21.3) | 18.9 (14.9-22.7) |
| 60-day | 10.3 (9.68-10.9) | 11.4 (10.8-12.2) | 13.2 (12.4-14.1) | 14.6 (13.6-15.6) | 16.3 (14.7-17.6) | 17.5 (15.5-19.2) | 18.5 (16.0-20.7) | 19.5 (16.3-22.3) | 20.6 (16.6-24.1) | 21.3 (16.9-25.5) |

¹ Precipitation frequency (PF) estimates in this table are based on frequency analysis of partial duration series (PDS). Numbers in parenthesis are PF estimates at lower and upper bounds of the 90% confidence interval. The probability that precipitation frequency estimates (for a given duration and average recurrence interval) will be greater than the upper bound (or less than the lower bound) is 5%. Estimates at upper bounds are not checked against probable maximum precipitation (PMP) estimates and may be higher than currently valid PMP values.





| | | | | | |
|----------------|--|-------------|--------------|-------------|--------------|
| Client | WEC Energy Group | | | Page | 3 of 4 |
| Project | Caledonia LF Run-on and Run-off Control Plan | | | Rev. | 0 |
| By | W. Reybrock | Chk. | A. Schwoerer | App. | A. Schwoerer |
| Date | 10/03/2016 | Date | 8/30/21 | Date | 8/30/21 |

| | | | |
|------------------------|--|---------------------|-----|
| GEI Project No. | 1610530 | Document No. | N/A |
| Subject | NOAA 14, Vol. 8 Rainfall Analysis and Run-off Volume | | |

Graphical Output from the PFDS:

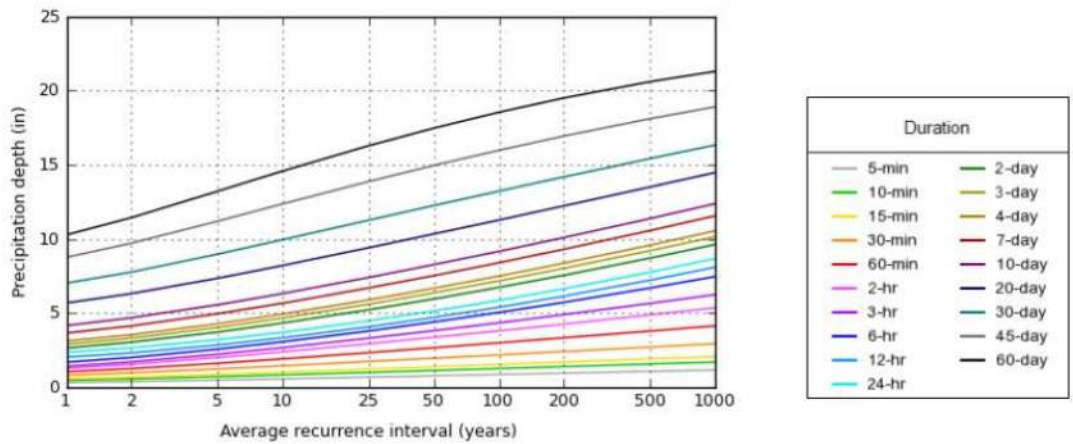
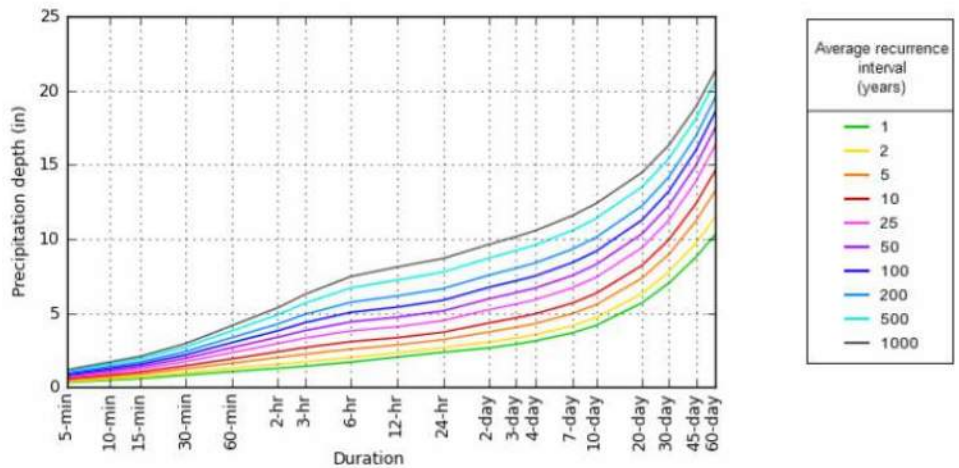
PDS-based depth-duration-frequency (DDF) curves
Latitude: 42.8374°, Longitude: -87.8415°



| | | | | | | |
|--|--|--|-------------|--------------|-------------|--------------|
|  | Client | WEC Energy Group | | | Page | 4 of 4 |
| | Project | Caledonia LF Run-on and Run-off Control Plan | | | Rev. | 0 |
| | By | W. Reybrock | Chk. | A. Schwoerer | App. | A. Schwoerer |
| | Date | 10/03/2016 | Date | 8/30/21 | Date | 8/30/21 |
| GEI Project No. | 1610530 | Document No. | N/A | | | |
| Subject | NOAA 14, Vol. 8 Rainfall Analysis and Run-off Volume | | | | | |
| Regulations: | | | | | | |
| <p>The Caledonia Landfill is regulated under 40 CFR Part 257 Subpart D – Standards for Disposal of Coal Combustion Residuals (CCR) in Landfills and Surface Impoundments as an existing landfill. The regulations specify that landfill must have the following plans in place:</p> <ul style="list-style-type: none"> • A run-on control system to prevent flow onto the active portion of the CCR unit during the peak discharge from a 24-hour, 25-year storm. • A run-off control system from the active portion of the CCR unit to collect and control at least the water volume resulting from a 24-hour, 25-year storm. | | | | | | |
| Conclusion: | | | | | | |
| <p>The 24-hour, 25-year storm for the Caledonia Landfill is 4.48 inches. This value will be utilized in the stormwater run-off model (under a separate calculation package).</p> | | | | | | |

Appendix C

Stormwater Run-on Calculations

| | | | | | | |
|---|--------------------------------|--|-------------|--------------|-------------|--------------|
|  | Client | We Energies | | | Page | 1 of 2 |
| | Project | Caledonia Ash Landfill Run-on and Run-off Control Plan | | | Rev. | 0 |
| | By | W. Reybrock | Chk. | A. Schwoerer | App. | A. Schwoerer |
| | Date | 07/26/2021 | Date | 8/30/21 | Date | 8/30/21 |
| GEI Project No. | 1610530 | Document No. | N/A | | | |
| Subject | Stormwater Run-on Calculations | | | | | |

Purpose:

The purpose of this calculation is to model and confirm the current run-on control system for the Caledonia Ash Landfill can adequately manage a 24-hour, 25-year precipitation event.

Design Criteria and Assumptions:

1. The rainfall depth estimation for the 24-hr, 25-yr event is 4.48 inches. The rainfall depth was determined by following procedures outlined in Precipitation-Frequency (PF) Atlas of the United States (Atlas 14, Volume 8, Version 2: Wisconsin). (See Appendix B)
2. On the east and west sides of the landfill, stormwater ditches between the access road and the landfill perimeter berm conveys stormwater to the detention basin southeast of the landfill. On the east the ditch is routed directly to the detention basin. On the west the stormwater is routed south, through a culvert running under the site screening berm, and then east to the detention basin.
3. Along the north side of the landfill, a stormwater run-on control ditch runs west to east along the entire length of Cell 10. The ditch intercepts and prevents stormwater run-on from entering Cell 10. The ditch redirect the run-on to the east perimeter ditch and eventually the stormwater detention basin.
4. Stormwater modeling was completed to confirm that the current run-on control system on the north side of the landfill is sufficiently sized to manage a 24-hr, 25-yr precipitation event.
5. HydroCAD 10.0 was used to model the stormwater run-on.
6. The stormwater run-on control ditch is 2-feet-deep with 3H:1V side slopes.
7. Subcatchment and reach parameters are included in the attached HydroCAD Report.

Results:

Based on stormwater model, the current run-on control system on the north side of the Caledonia Ash Landfill is able to handle the 24-hr, 25-yr precipitation event without allowing run-on stormwater to enter the landfill. The estimated peak water level in the channel is 1.2 feet; which is less than the 2-feet-deep channel. The conveyance channel north of the intercell berm is adequately sized to prevent run-on to Cell 10 associated with the 24-hour, 25-year precipitation event.

Attachments:

- Figure 1 – Stormwater Flow Diagram
- HydroCAD Summary Report

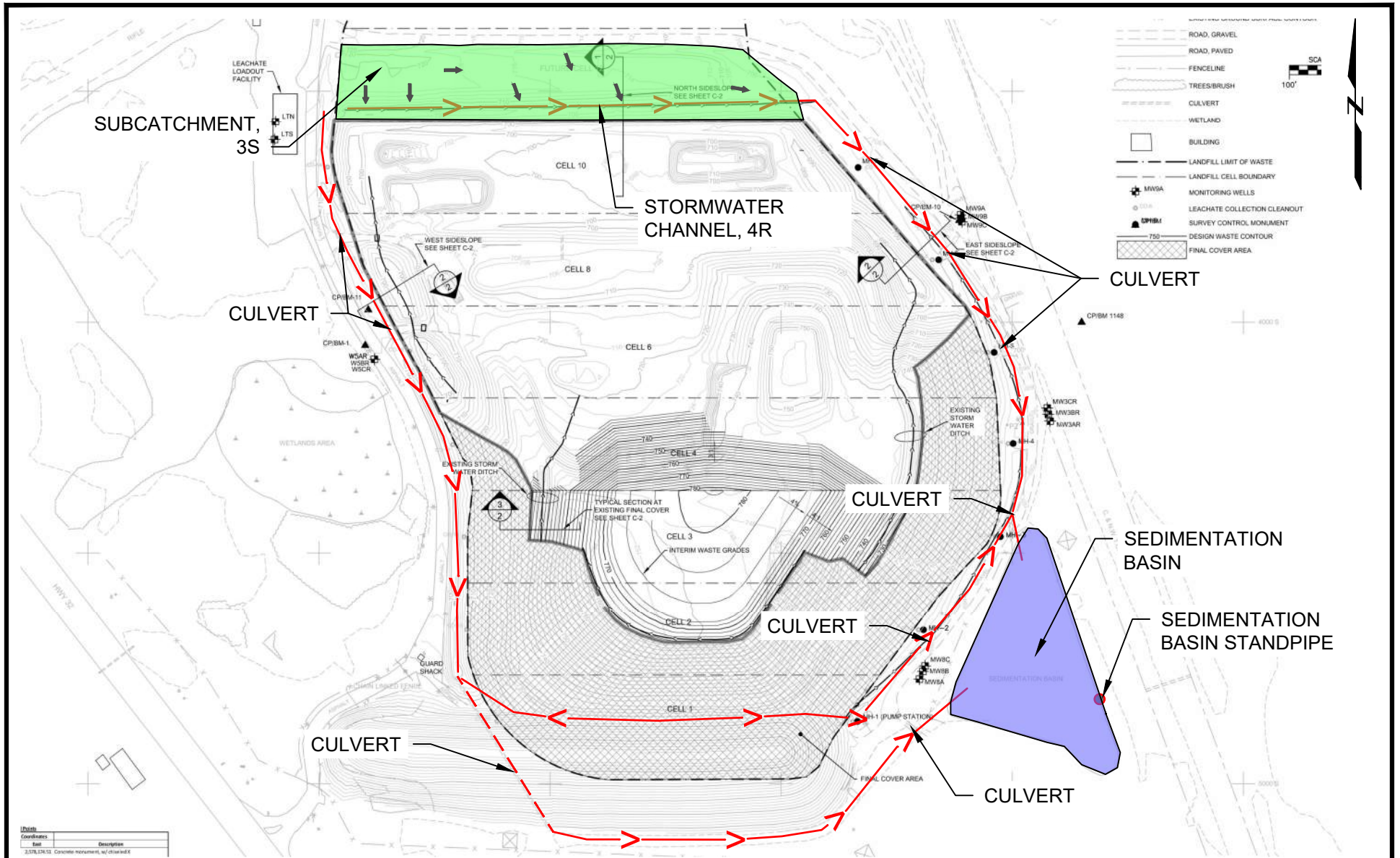

SOURCE:

1. PLAN BASED ON DWG C-1, CALEDONIA ASH LANDFILL, SUBMITTAL DATE 7/19/2021

Run-on and Run-off Control Plan
 Caledonia Ash Landfill
 Caledonia, Wisconsin

We Energies
 Milwaukee, Wisconsin



Run-On Stormwater Flow Diagram

Project 1610530

August 2021

Fig. 1

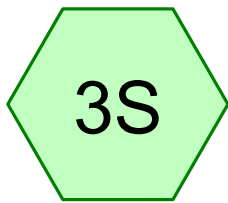

North Side Catchment

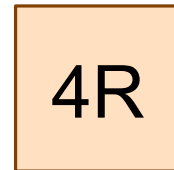
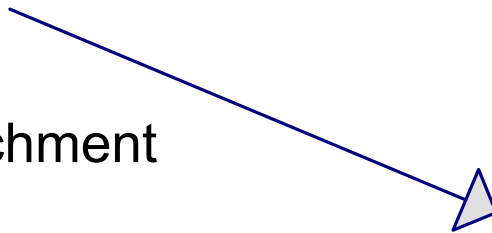

Stormwater Ditch (west to east)

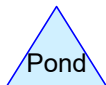
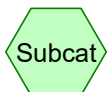

C1601530_WEC_Caledonia_SW_Runon_2021

Prepared by GEI Consultants

HydroCAD® 10.00-25 s/n 11294 © 2019 HydroCAD Software Solutions LLC

Printed 7/24/2021

Page 2

Area Listing (all nodes)

| Area (acres) | CN | Description (subcatchment-numbers) |
|-----------------|-----------|---------------------------------------|
| 3.547 | 86 | <50% Grass cover, Poor, HSG C (3S) |
| 3.547 | 86 | TOTAL AREA |

C1601530_WEC_Caledonia_SW_Runon_2021

Prepared by GEI Consultants

HydroCAD® 10.00-25 s/n 11294 © 2019 HydroCAD Software Solutions LLC

Printed 7/24/2021

Page 3

Soil Listing (all nodes)

| Area (acres) | Soil Group | Subcatchment Numbers |
|-----------------|---------------|-------------------------|
| 0.000 | HSG A | |
| 0.000 | HSG B | |
| 3.547 | HSG C | 3S |
| 0.000 | HSG D | |
| 0.000 | Other | |
| 3.547 | | TOTAL AREA |

C1601530_WEC_Caledonia_SW_Runon_2021

Prepared by GEI Consultants

HydroCAD® 10.00-25 s/n 11294 © 2019 HydroCAD Software Solutions LLC

Printed 7/24/2021

Page 4

Ground Covers (all nodes)

| HSG-A (acres) | HSG-B (acres) | HSG-C (acres) | HSG-D (acres) | Other (acres) | Total (acres) | Ground Cover | Subcatchment Numbers |
|------------------|------------------|------------------|------------------|------------------|------------------|------------------------|-------------------------|
| 0.000 | 0.000 | 3.547 | 0.000 | 0.000 | 3.547 | <50% Grass cover, Poor | 3S |
| 0.000 | 0.000 | 3.547 | 0.000 | 0.000 | 3.547 | TOTAL AREA | |

Time span=0.00-72.00 hrs, dt=0.05 hrs, 1441 points
Runoff by SCS TR-20 method, UH=SCS, Weighted-CN
Reach routing by Stor-Ind+Trans method - Pond routing by Stor-Ind method

Subcatchment3S: North Side Catchment Runoff Area=154,524 sf 0.00% Impervious Runoff Depth=2.98"
Flow Length=122' Slope=0.0492 '/' Tc=1.1 min CN=86 Runoff=20.28 cfs 0.882 af

Reach 4R: Stormwater Ditch (west to Avg. Flow Depth=1.24' Max Vel=3.69 fps Inflow=20.28 cfs 0.882 af
n=0.022 L=1,000.0' S=0.0061 '/' Capacity=61.12 cfs Outflow=16.08 cfs 0.882 af

Total Runoff Area = 3.547 ac Runoff Volume = 0.882 af Average Runoff Depth = 2.98"
100.00% Pervious = 3.547 ac 0.00% Impervious = 0.000 ac

Summary for Subcatchment 3S: North Side Catchment

[49] Hint: $T_c < 2dt$ may require smaller dt

Runoff = 20.28 cfs @ 11.90 hrs, Volume= 0.882 af, Depth= 2.98"

Runoff by SCS TR-20 method, UH=SCS, Weighted-CN, Time Span= 0.00-72.00 hrs, dt= 0.05 hrs
 Type II 24-hr 25-yr, 24-hr Rainfall=4.48"

| Area (sf) | CN | Description |
|-----------|----|-------------------------------|
| 154,524 | 86 | <50% Grass cover, Poor, HSG C |
| 154,524 | | 100.00% Pervious Area |

| Tc (min) | Length (feet) | Slope (ft/ft) | Velocity (ft/sec) | Capacity (cfs) | Description |
|----------|---------------|---------------|-------------------|----------------|---|
| 1.1 | 122 | 0.0492 | 1.87 | | Sheet Flow, Side slope Smooth surfaces n= 0.011 P2= 2.66" |

Subcatchment 3S: North Side Catchment

Hydrograph

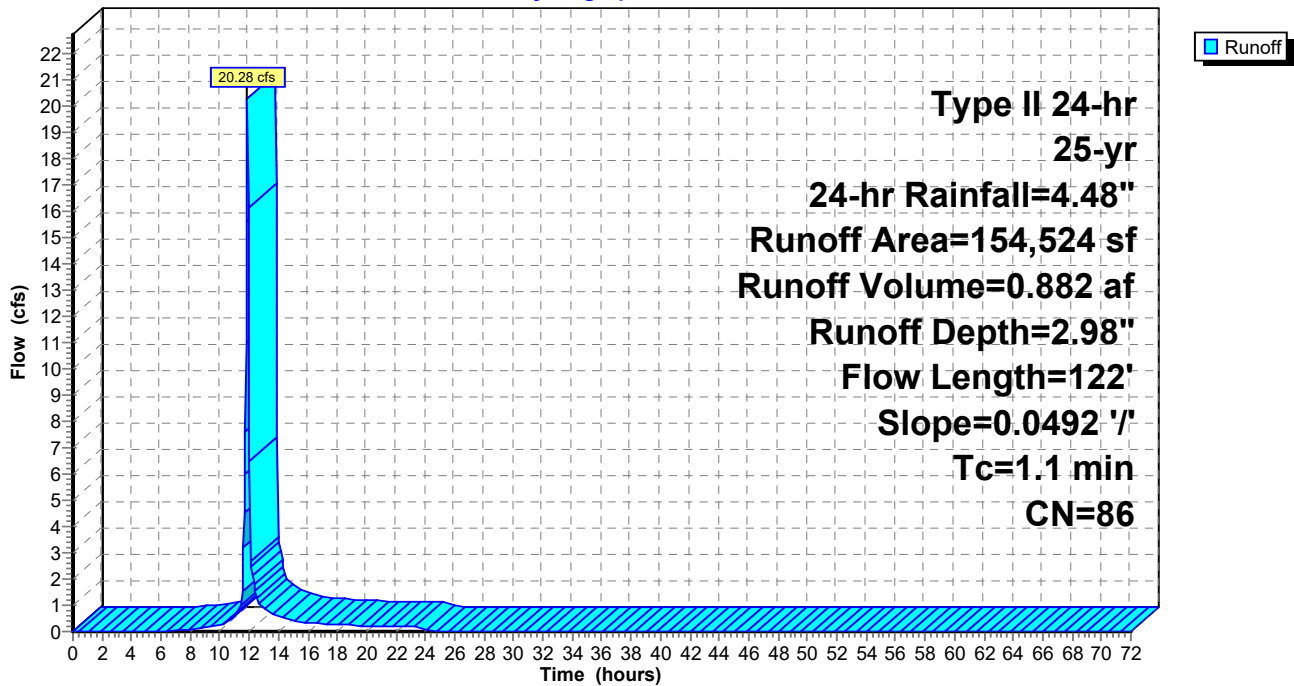

Summary for Reach 4R: Stormwater Ditch (west to east)

Inflow Area = 3.547 ac, 0.00% Impervious, Inflow Depth = 2.98" for 25-yr, 24-hr event
 Inflow = 20.28 cfs @ 11.90 hrs, Volume= 0.882 af
 Outflow = 16.08 cfs @ 12.02 hrs, Volume= 0.882 af, Atten= 21%, Lag= 6.9 min

Routing by Stor-Ind+Trans method, Time Span= 0.00-72.00 hrs, dt= 0.05 hrs
 Max. Velocity= 3.69 fps, Min. Travel Time= 4.5 min
 Avg. Velocity = 1.10 fps, Avg. Travel Time= 15.2 min

Peak Storage= 4,584 cf @ 11.94 hrs
 Average Depth at Peak Storage= 1.24'
 Bank-Full Depth= 2.00' Flow Area= 12.0 sf, Capacity= 61.12 cfs

0.00' x 2.00' deep channel, n= 0.022 Earth, clean & straight
 Side Slope Z-value= 3.0 '/' Top Width= 12.00'
 Length= 1,000.0' Slope= 0.0061 '/'
 Inlet Invert= 710.00', Outlet Invert= 703.90'

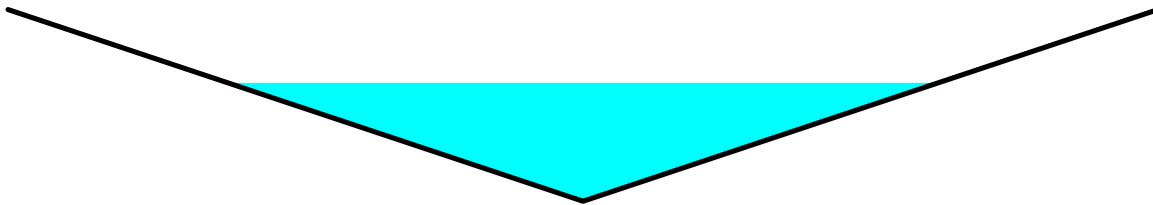

Reach 4R: Stormwater Ditch (west to east)

Hydrograph

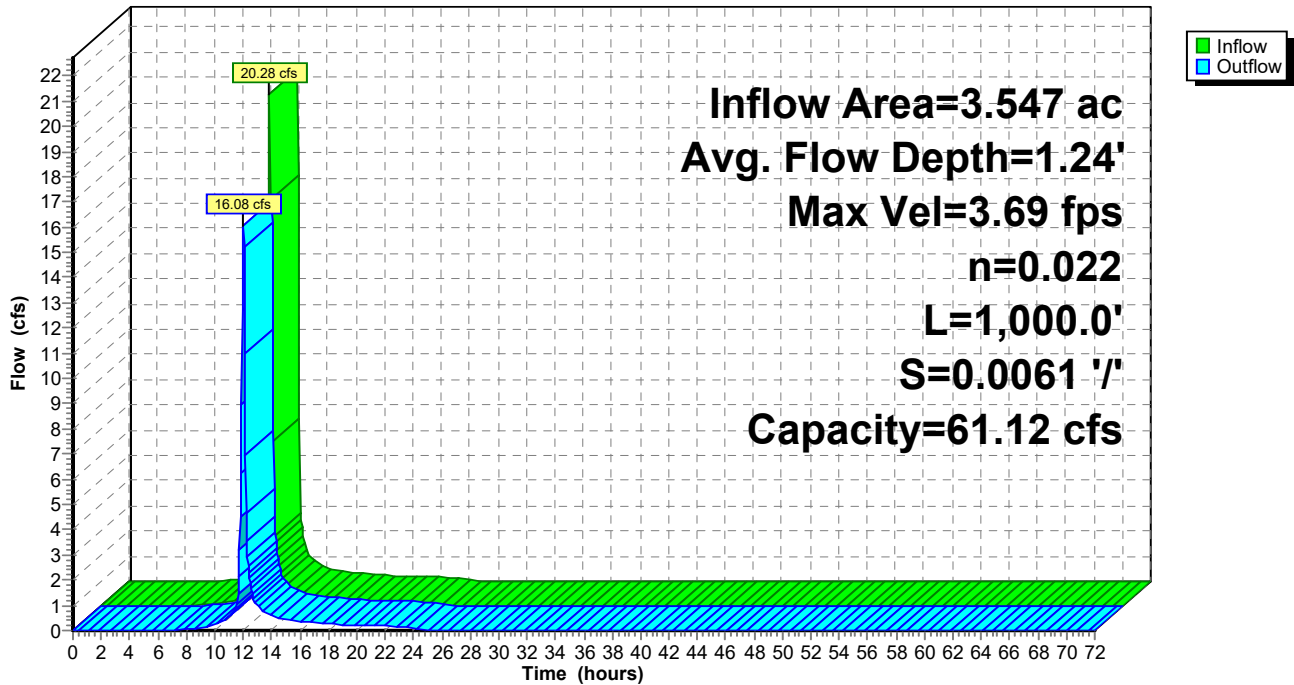

Appendix D

Stormwater Run-off Calculations

| | | | | | | |
|---|---------------------------------|--|-------------|--------------|-------------|--------------|
|  | Client | We Energies | | | Page | 1 of 2 |
| | Project | Caledonia Ash Landfill Run-on and Run-off Control Plan | | | Rev. | 0 |
| | By | W. Reybrock | Chk. | A. Schwoerer | App. | A. Schwoerer |
| | Date | 7/27/2021 | Date | 8/30/21 | Date | 8/30/21 |
| GEI Project No. | 1610530 | Document No. | N/A | | | |
| Subject | Stormwater Run-off Calculations | | | | | |
| Purpose: | | | | | | |
| <p>The purpose of this calculation is to model and confirm the current run-off control system for the construction of landfill can adequately manage the stormwater run-off associated with 24-hour, 25-year precipitation event at Caledonia Ash Landfill.</p> | | | | | | |
| Design Criteria and Assumptions: | | | | | | |
| <ol style="list-style-type: none"> 1. The rainfall depth estimation for the 24-hour, 25-year event is 4.48 inches. The rainfall depth was determined by following procedures outlined in Precipitation-Frequency (PF) Atlas of the United States (Atlas 14, Volume 8, Version 2: Wisconsin). (See Appendix B) 2. Stormwater on the Cell was divided into five subcatchments: west side slope, southwest side slope, north slope, southeast side slope, and the stormwater surge area, as shown on Figure 1. 3. HydroCAD 10.0 was used to model the stormwater associated with the Caledonia Ash Landfill. 4. The attached HydroCAD Report details the Subcatchment, reach, and pond parameters of the model. 5. In general, contact stormwater sheet flows to temporary stormwater ditches on the inside of the landfill, which are routed to a temporary stormwater surge area on the east side of Cell 8 and Cell 10, where the stormwater is allowed to infiltrate into the leachate collection system. 6. The model evaluated is the intermediate filling condition where Cells 2 and 3 have reached final waste grades as shown on Drawing C-1. 7. Stormwater on the intermediate filling condition is divided into five (5) subcatchments: west side slope, southwest side slope, north slope, southeast side slope, and the stormwater surge area, as shown on Figure 1. Stormwater for the subcatchments is routed as sheet flow and shallow concentrated flow either directly into an intercell stormwater surge area or as sheet flow until the water is intercepted by temporary stormwater channels. In general, the intermediate filling condition perimeter channels are a minimum of 3 feet deep and have a 2H:1V interior and 2H:1V (within ash) or 3H:1V (granular drainage layer) exterior slopes depending on the location within the landfill. 8. Contact stormwater from perimeter channels is conveyed to the stormwater surge area. Stormwater in the surge area is allowed infiltrate through the granular drainage layer into the leachate collection system and is treated as leachate. | | | | | | |

| | | | | | | |
|---|---------------------------------|--|-------------|--------------|-------------|--------------|
|  | Client | We Energies | | | Page | 2 of 2 |
| | Project | Caledonia Ash Landfill Run-on and Run-off Control Plan | | | Rev. | 0 |
| | By | W. Reybrock | Chk. | A. Schwoerer | App. | A. Schwoerer |
| | Date | 7/27/2021 | Date | 8/30/21 | Date | 8/30/21 |
| GEI Project No. | 1610530 | Document No. | N/A | | | |
| Subject | Stormwater Run-off Calculations | | | | | |
| Results: | | | | | | |
| <p>Based on the analysis, the run-off control system for the Caledonia Ash Landfill is able to contain, manage, and control the run-off from a 24-hour, 25-year precipitation event without allowing any contact water to escape the constructed limits of the landfill. The intercell stormwater surge area has a minimum crest elevation of El. 700.0 feet, and the estimated water level associated with the 24-hour, 25-year storm event is El. 695.64 feet. Both the temporary stormwater containment ditches and the stormwater surge area are designed to contain, manage, and control the run-off from the landfill associated with the 24-hour, 25-year storm event.</p> | | | | | | |
| Attachments: | | | | | | |
| <ul style="list-style-type: none"> • Figure 1 – Stormwater • HydroCAD Summary Report | | | | | | |

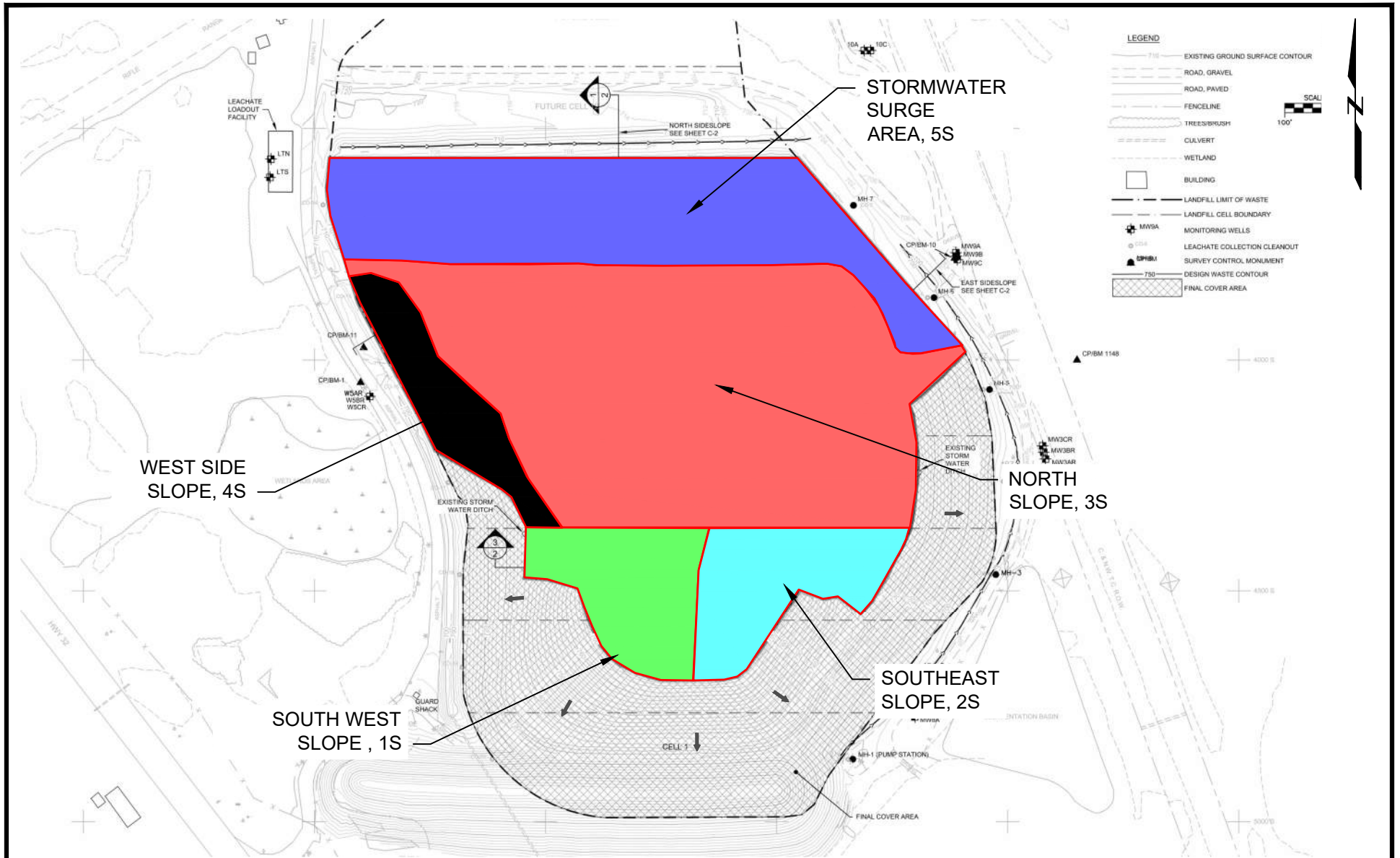

SOURCE:

1. PLAN BASED ON DWG C-1, CALEDONIA ASH LANDFILL, SUBMITTAL DATE 7/19/2021

Run-on and Run-off Control Plan
 Caledonia Ash Landfill
 Caledonia, Wisconsin

We Energies
 Milwaukee, Wisconsin



Run-Off Stormwater Flow Diagram

Project 1610530

September 2021

Fig. 1

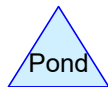
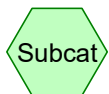
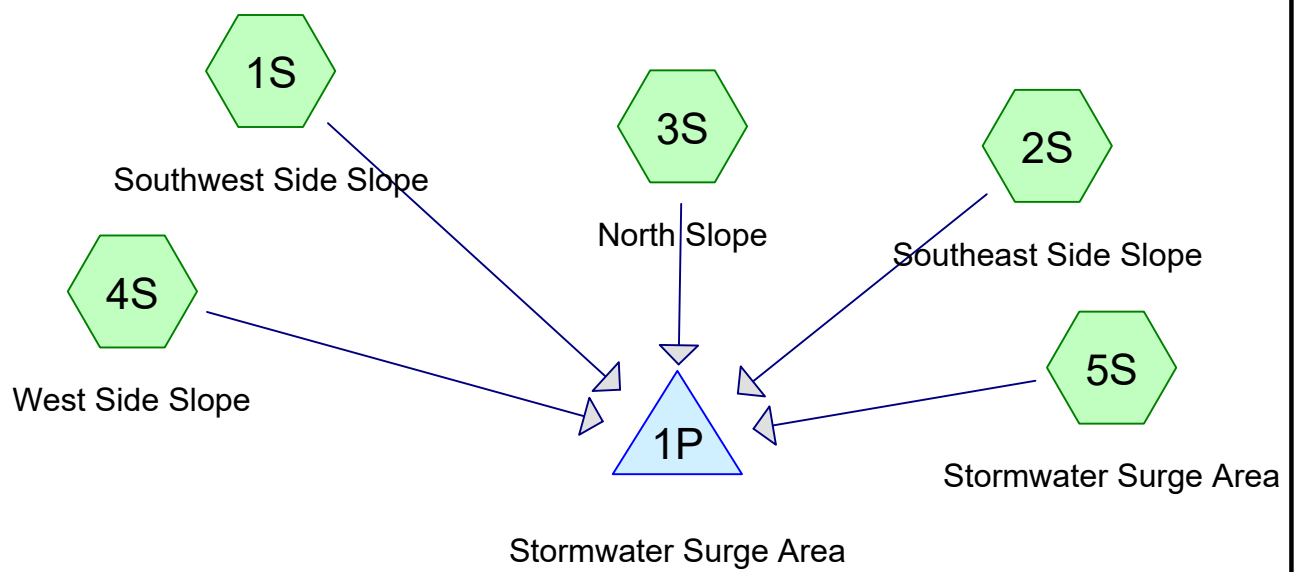

Routing Diagram for C1601530_WEC_Caledonia_SW_Runoff_202

Prepared by GEI Consultants, Printed 7/26/2021

HydroCAD® 10.00-25 s/n 11294 © 2019 HydroCAD Software Solutions LLC

C1601530_WEC_Caledonia_SW_Runoff_2021

Prepared by GEI Consultants

HydroCAD® 10.00-25 s/n 11294 © 2019 HydroCAD Software Solutions LLC

Printed 7/26/2021

Page 2

Area Listing (all nodes)

| Area (acres) | CN | Description (subcatchment-numbers) |
|-----------------|-----------|---|
| 17.941 | 91 | Newly graded area, HSG C (1S, 2S, 3S, 4S) |
| 6.302 | 98 | Water Surface, HSG C (5S) |
| 24.244 | 93 | TOTAL AREA |

C1601530_WEC_Caledonia_SW_Runoff_2021

Prepared by GEI Consultants

HydroCAD® 10.00-25 s/n 11294 © 2019 HydroCAD Software Solutions LLC

Printed 7/26/2021

Page 3

Soil Listing (all nodes)

| Area (acres) | Soil Group | Subcatchment Numbers |
|-----------------|---------------|-------------------------|
| 0.000 | HSG A | |
| 0.000 | HSG B | |
| 24.244 | HSG C | 1S, 2S, 3S, 4S, 5S |
| 0.000 | HSG D | |
| 0.000 | Other | |
| 24.244 | | TOTAL AREA |

C1601530_WEC_Caledonia_SW_Runoff_2021

Prepared by GEI Consultants

HydroCAD® 10.00-25 s/n 11294 © 2019 HydroCAD Software Solutions LLC

Printed 7/26/2021

Page 4

Ground Covers (all nodes)

| HSG-A (acres) | HSG-B (acres) | HSG-C (acres) | HSG-D (acres) | Other (acres) | Total (acres) | Ground Cover | Subcatchment Numbers |
|------------------|------------------|------------------|------------------|------------------|------------------|-------------------|-------------------------|
| 0.000 | 0.000 | 17.941 | 0.000 | 0.000 | 17.941 | Newly graded area | 1S, 2S, 3S, 4S |
| 0.000 | 0.000 | 6.302 | 0.000 | 0.000 | 6.302 | Water Surface | 5S |
| 0.000 | 0.000 | 24.244 | 0.000 | 0.000 | 24.244 | TOTAL AREA | |

Time span=0.00-72.00 hrs, dt=0.05 hrs, 1441 points
Runoff by SCS TR-20 method, UH=SCS, Weighted-CN
Reach routing by Stor-Ind+Trans method - Pond routing by Stor-Ind method

Subcatchment1S: Southwest Side Slope Runoff Area=89,106 sf 0.00% Impervious Runoff Depth=3.48"
Flow Length=860' Tc=4.1 min CN=91 Runoff=12.36 cfs 0.593 af

Subcatchment2S: Southeast Side Slope Runoff Area=90,715 sf 0.00% Impervious Runoff Depth=3.48"
Flow Length=920' Tc=3.7 min CN=91 Runoff=12.72 cfs 0.604 af

Subcatchment3S: North Slope Runoff Area=534,656 sf 0.00% Impervious Runoff Depth=3.48"
Flow Length=600' Tc=2.7 min CN=91 Runoff=76.04 cfs 3.558 af

Subcatchment4S: West Side Slope Runoff Area=67,044 sf 0.00% Impervious Runoff Depth=3.48"
Flow Length=600' Tc=37.7 min CN=91 Runoff=3.91 cfs 0.446 af

Subcatchment5S: Stormwater Surge Runoff Area=274,530 sf 100.00% Impervious Runoff Depth=4.24"
Tc=0.0 min CN=98 Runoff=45.11 cfs 2.229 af

Pond 1P: Stormwater Surge Area Peak Elev=695.64' Storage=323,624 cf Inflow=138.46 cfs 7.430 af
Outflow=0.00 cfs 0.000 af

Total Runoff Area = 24.244 ac Runoff Volume = 7.430 af Average Runoff Depth = 3.68"
74.00% Pervious = 17.941 ac 26.00% Impervious = 6.302 ac

Summary for Subcatchment 1S: Southwest Side Slope

[49] Hint: Tc<2dt may require smaller dt

Runoff = 12.36 cfs @ 11.94 hrs, Volume= 0.593 af, Depth= 3.48"

Runoff by SCS TR-20 method, UH=SCS, Weighted-CN, Time Span= 0.00-72.00 hrs, dt= 0.05 hrs
 Type II 24-hr 25-yr, 24-hr Rainfall=4.48"

| Area (sf) | CN | Description |
|-----------|----|--------------------------|
| * 89,106 | 91 | Newly graded area, HSG C |
| 89,106 | | 100.00% Pervious Area |

| Tc (min) | Length (feet) | Slope (ft/ft) | Velocity (ft/sec) | Capacity (cfs) | Description |
|----------|---------------|---------------|-------------------|----------------|---|
| 2.1 | 250 | 0.0400 | 1.99 | | Sheet Flow, Top of slope Smooth surfaces n= 0.011 P2= 2.66" |
| 0.3 | 60 | 0.2500 | 3.11 | | Sheet Flow, Side Slope Smooth surfaces n= 0.011 P2= 2.66" |
| 1.7 | 550 | 0.0200 | 5.55 | 18.22 | Trap/Vee/Rect Channel Flow, stormwater ditch perimeter Bot.W=5.00' D=0.54' Z= 2.0 '/' Top.W=7.16' n= 0.022 Earth, clean & straight |
| 4.1 | 860 | Total | | | |

Subcatchment 1S: Southwest Side Slope

Hydrograph

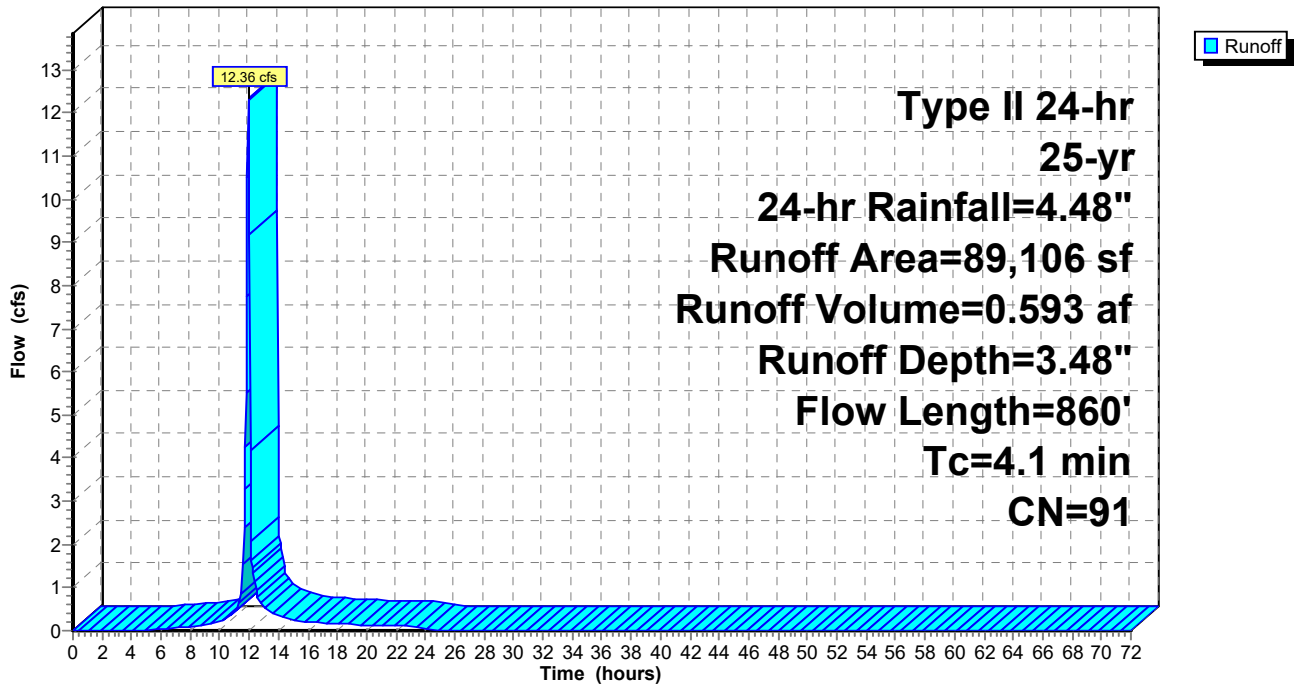

Summary for Subcatchment 2S: Southeast Side Slope

[49] Hint: Tc<2dt may require smaller dt

Runoff = 12.72 cfs @ 11.94 hrs, Volume= 0.604 af, Depth= 3.48"

Runoff by SCS TR-20 method, UH=SCS, Weighted-CN, Time Span= 0.00-72.00 hrs, dt= 0.05 hrs
 Type II 24-hr 25-yr, 24-hr Rainfall=4.48"

| Area (sf) | CN | Description |
|-----------|----|--------------------------|
| 90,715 | 91 | Newly graded area, HSG C |
| 90,715 | | 100.00% Pervious Area |

| Tc (min) | Length (feet) | Slope (ft/ft) | Velocity (ft/sec) | Capacity (cfs) | Description |
|----------|---------------|---------------|-------------------|----------------|---|
| 1.8 | 200 | 0.0400 | 1.90 | | Sheet Flow, Top of slope Smooth surfaces n= 0.011 P2= 2.66" |
| 0.2 | 40 | 0.2500 | 2.87 | | Sheet Flow, Side Slope Smooth surfaces n= 0.011 P2= 2.66" |
| 1.7 | 680 | 0.0300 | 6.80 | 22.31 | Trap/Vee/Rect Channel Flow, stormwater ditch perimeter Bot.W=5.00' D=0.54' Z= 2.0 '/' Top.W=7.16' n= 0.022 Earth, clean & straight |
| 3.7 | 920 | Total | | | |

Subcatchment 2S: Southeast Side Slope

Hydrograph

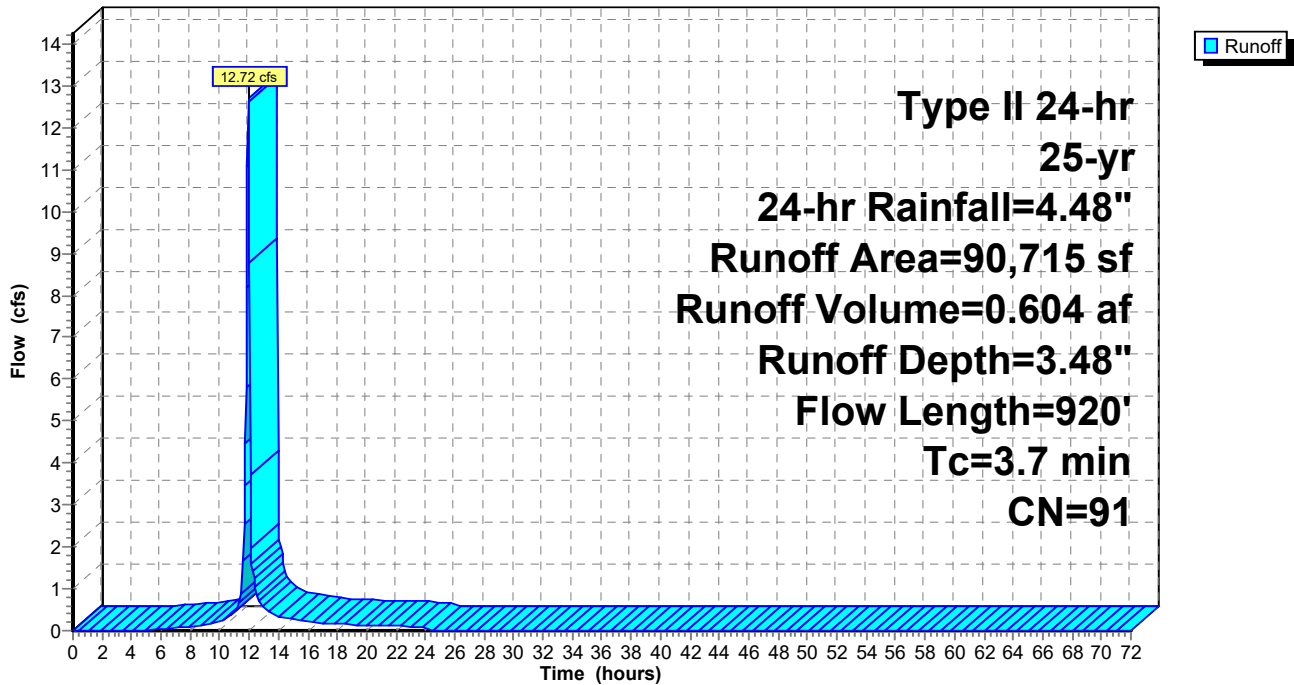

Summary for Subcatchment 3S: North Slope

[49] Hint: $T_c < 2dt$ may require smaller dt

Runoff = 76.04 cfs @ 11.93 hrs, Volume= 3.558 af, Depth= 3.48"

Runoff by SCS TR-20 method, UH=SCS, Weighted-CN, Time Span= 0.00-72.00 hrs, dt= 0.05 hrs
 Type II 24-hr 25-yr, 24-hr Rainfall=4.48"

| Area (sf) | CN | Description |
|-----------|----|--------------------------|
| * 534,656 | 91 | Newly graded area, HSG C |
| 534,656 | | 100.00% Pervious Area |

| Tc (min) | Length (feet) | Slope (ft/ft) | Velocity (ft/sec) | Capacity (cfs) | Description |
|----------|---------------|---------------|-------------------|----------------|--|
| 1.0 | 300 | 0.3333 | 4.81 | | Sheet Flow, Side Slope Smooth surfaces n= 0.011 P2= 2.66" |
| 1.7 | 300 | 0.0900 | 3.00 | | Shallow Concentrated Flow, north slope shallow Nearly Bare & Untilled Kv= 10.0 fps |
| 2.7 | 600 | Total | | | |

Subcatchment 3S: North Slope

Hydrograph

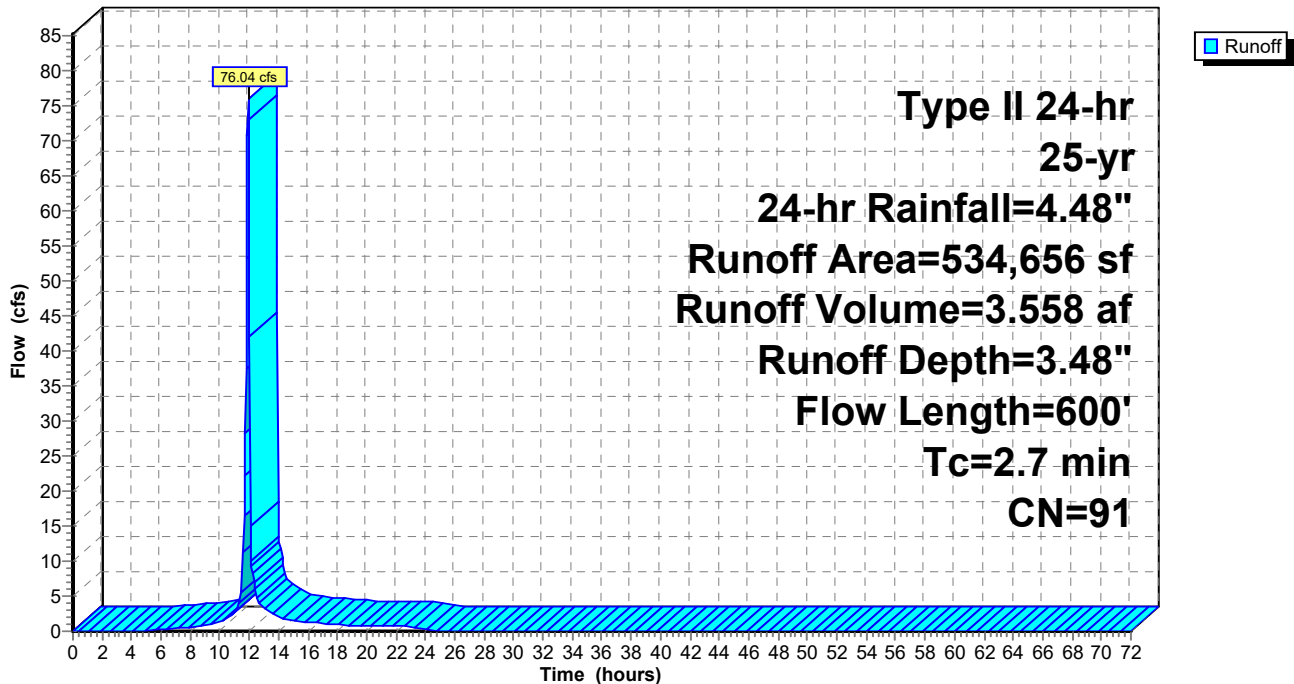

Summary for Subcatchment 4S: West Side Slope

Runoff = 3.91 cfs @ 12.32 hrs, Volume= 0.446 af, Depth= 3.48"

Runoff by SCS TR-20 method, UH=SCS, Weighted-CN, Time Span= 0.00-72.00 hrs, dt= 0.05 hrs
 Type II 24-hr 25-yr, 24-hr Rainfall=4.48"

| Area (sf) | CN | Description |
|-----------|----|--------------------------|
| * 67,044 | 91 | Newly graded area, HSG C |
| 67,044 | | 100.00% Pervious Area |

| Tc (min) | Length (feet) | Slope (ft/ft) | Velocity (ft/sec) | Capacity (cfs) | Description |
|----------|---------------|---------------|-------------------|----------------|--|
| 0.4 | 100 | 0.3330 | 3.86 | | Sheet Flow, Top of slope Smooth surfaces n= 0.011 P2= 2.66" |
| 37.3 | 500 | 0.0005 | 0.22 | | Shallow Concentrated Flow, flow to the north cell 10 Nearly Bare & Untilled Kv= 10.0 fps |
| 37.7 | 600 | Total | | | |

Subcatchment 4S: West Side Slope

Hydrograph

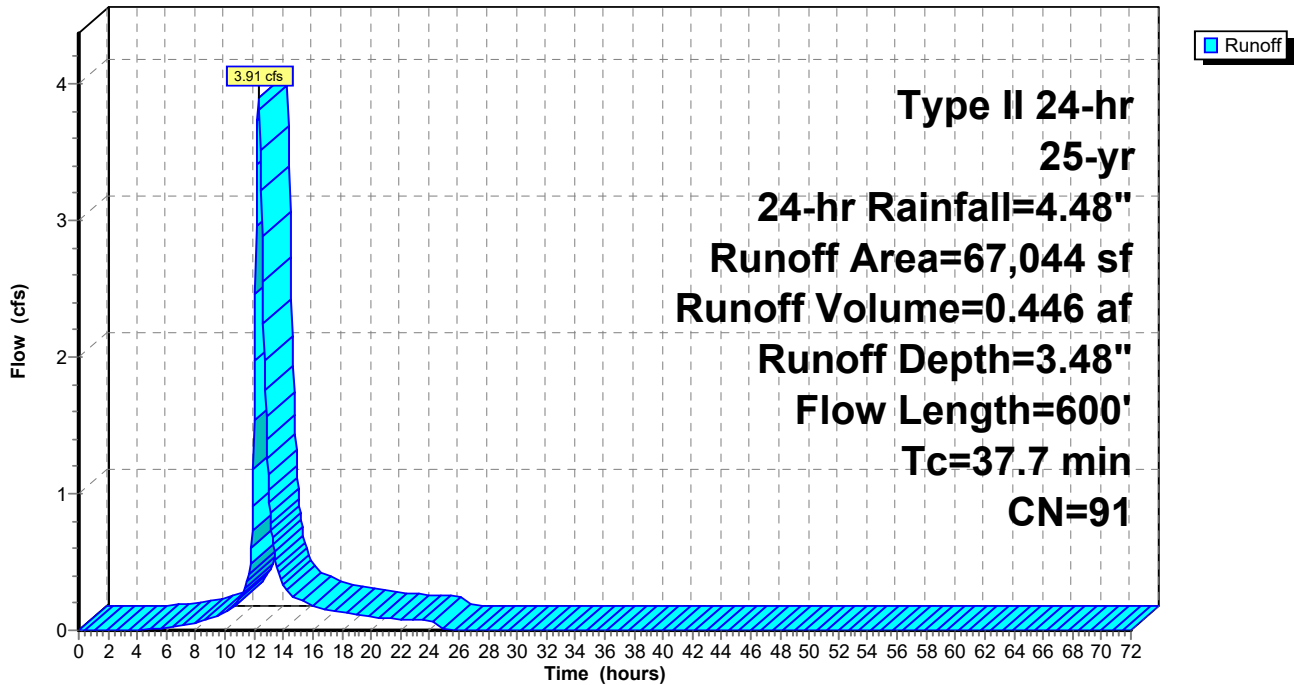

Summary for Subcatchment 5S: Stormwater Surge Area

[46] Hint: Tc=0 (Instant runoff peak depends on dt)

Runoff = 45.11 cfs @ 11.89 hrs, Volume= 2.229 af, Depth= 4.24"

Runoff by SCS TR-20 method, UH=SCS, Weighted-CN, Time Span= 0.00-72.00 hrs, dt= 0.05 hrs
 Type II 24-hr 25-yr, 24-hr Rainfall=4.48"

| Area (sf) | CN | Description |
|-----------|----|-------------------------|
| 274,530 | 98 | Water Surface, HSG C |
| 274,530 | | 100.00% Impervious Area |

Subcatchment 5S: Stormwater Surge Area

Hydrograph

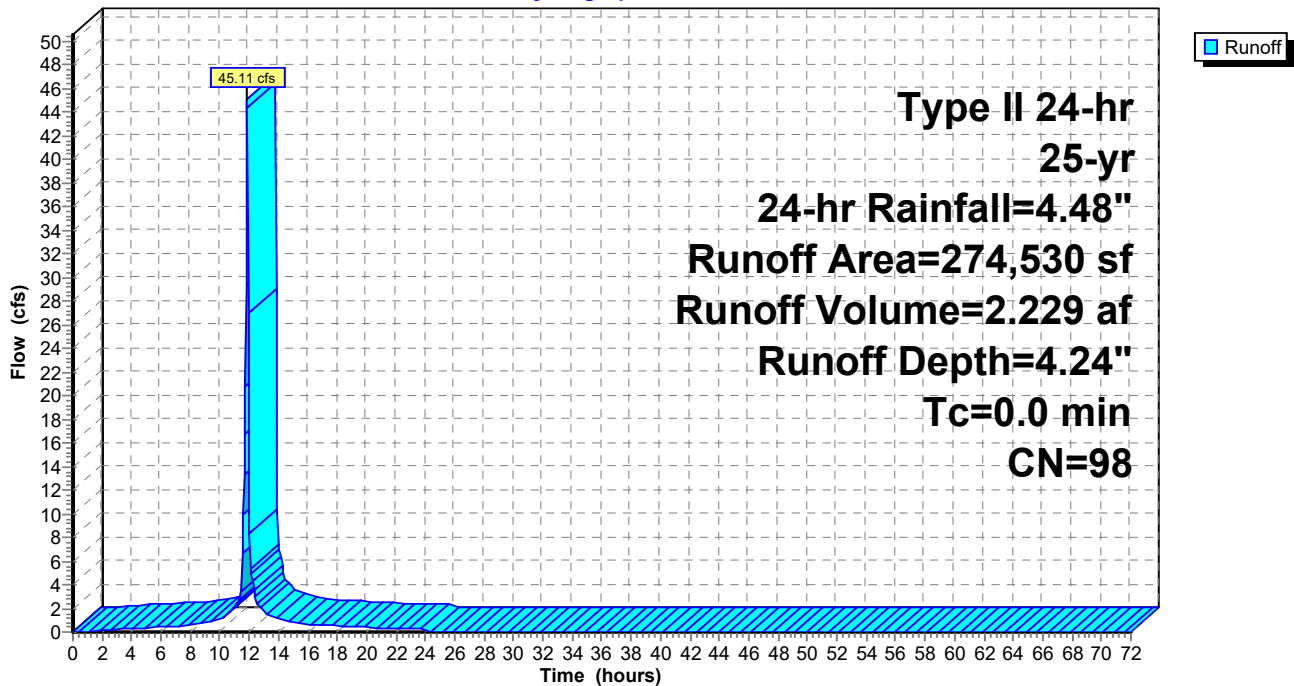

Summary for Pond 1P: Stormwater Surge Area

Inflow Area = 24.244 ac, 26.00% Impervious, Inflow Depth = 3.68" for 25-yr, 24-hr event
 Inflow = 138.46 cfs @ 11.91 hrs, Volume= 7.430 af
 Outflow = 0.00 cfs @ 0.00 hrs, Volume= 0.000 af, Atten= 100%, Lag= 0.0 min

Routing by Stor-Ind method, Time Span= 0.00-72.00 hrs, dt= 0.05 hrs
 Peak Elev= 695.64' @ 26.20 hrs Surf.Area= 119,103 sf Storage= 323,624 cf

Plug-Flow detention time= (not calculated: initial storage exceeds outflow)
 Center-of-Mass det. time= (not calculated: no outflow)

| Volume | Invert | Avail.Storage | Storage Description |
|--------|---------|---------------|--|
| #1 | 690.00' | 1,091,327 cf | Custom Stage Data (Prismatic) Listed below (Recalc) |

| Elevation (feet) | Surf.Area (sq-ft) | Inc.Store (cubic-feet) | Cum.Store (cubic-feet) |
|------------------|-------------------|------------------------|------------------------|
| 690.00 | 2,259 | 0 | 0 |
| 692.00 | 38,418 | 40,677 | 40,677 |
| 694.00 | 80,466 | 118,884 | 159,561 |
| 696.00 | 127,464 | 207,930 | 367,491 |
| 698.00 | 180,961 | 308,425 | 675,916 |
| 700.00 | 234,450 | 415,411 | 1,091,327 |

Pond 1P: Stormwater Surge Area

Hydrograph

