

UNDERGROUND SERVICES – SECONDARY

General requirements for underground service	U-2
Reference	
Name of parts for underground service	U-3
Typical number and size of service lateral conduits installed	U-3
Conduit layouts.....	U-4
Service termination in a service assembly for mobile homes	
1 or 2 meters, 1Ø, 120/240 volt, 0-200A per meter.....	U-5
Service termination in a meter pedestal, direct buried lateral (0-320A)	
Free standing, 1 meter.....	U-6
Attached to a building	U-7
Service termination in a multi-position meter socket	
Direct buried lateral	U-8
Service termination in an outdoor meter socket	
Temporary service.....	U-9
Service termination in a transocket	
Freestanding & temporary service	U-10
Freestanding for farm services only	U-11
Outdoor concrete encased lateral	U-12
Outdoor direct buried or direct buried conduit lateral	U-13
Padmounted – bottom entry and exit.....	U-14
First floor installation, concrete encased lateral	U-15
First floor installation, direct buried lateral	U-16
Service termination in a termination compartment	
General information	U-17
All outdoor laterals.....	U-18
Above grade – bottom entry and exit.....	U-20
Free standing – bottom entry and exit	U-22
Padmounted – bottom entry and exit.....	U-24
Concrete encased lateral – multi-metered installations.....	U-25
Building without a basement – first floor installation – multi-metered installations	U-26
Concrete encased lateral – located below grade *conduit and manhole system only*	U-28
Free standing switchgear – located below grade – for areas served by conduit and cable only.....	U-29
Free standing switchgear – located on first floor or above	U-30
Communication towers	
Policy on services	U-31
Service termination in a free standing multi-position meter socket – direct buried lateral.....	U-32

GENERAL REQUIREMENTS FOR UNDERGROUND SERVICE

Space Requirements

1. The unobstructed space required in front of termination compartments, transockets, and metering equipment shall be as defined by the "Working Space About Electrical Equipment," Section 110.26 of the **National Electric Code** (as adopted by the states Michigan and Wisconsin). This unobstructed space shall extend from the floor, or ground, to a minimum height of 6'-6". For equipment higher than 6'-6", this space shall extend to the top of the equipment.

Service Laterals and Entrances

1. Service laterals are furnished and installed by the Company.
2. Service laterals will generally be terminated in a meter pedestal, transockets, or termination compartment. Customers shall obtain information from the Company relative to the proper location of service lateral and termination equipment. Such information will be furnished in writing upon request.
3. The preferred termination of service laterals is on the outside of a building (or structure). Service laterals that terminate inside of a building shall terminate immediately upon entering as shown in this manual. The raceway for service laterals under or through a building shall not extend longer than 8' after penetrating the outside wall. **This 8' rule is a We Energies 8' requirement in addition to the SPS 316 8' requirement.** NEC article 230.6, *Conductors Considered Outside the Building*, are not exempt from the We Energies 8' rule. Services that terminate in a mezzanine are allowed a maximum length of 14' measured from grade.
4. With Company approval, service laterals, generally 2000 Amp or larger, may be terminated in the customer's switchgear or on the customer's bus duct. This type of installation is further restricted by the following:
 - a. Customer shall provide all necessary plastic conduit encased in 3" of concrete for the extension of the cable within his building (see Note 3 above).
 - b. Customer shall obtain Company acceptance of the switchgear termination and C.T. compartment design. **A copy of the switchgear plans shall be submitted to the local We Energies job representative for acceptance.** The plans must show the general layout of the switchgear, the switchgear location within the building, and the specific details of the termination compartment and any C.T. compartment(s). Specific details such as compartment size, bus spacing and drilling dimensions, other clearances, bus and bus support configuration, barrier location, sealing provisions, and materials used are to be included.
5. Only meter mounting devices and termination equipment approved and listed in **Section D** of this manual are to be used. Additionally, all equipment must be listed by a nationally recognized testing laboratory, e.g. UL, installed, and used as per the listing and the manufacturer's instructions.
6. Where metallic rigid conduit or IMC is used for the service lateral conduit, the ends are to be threaded and threaded couplings, connectors, or locknuts are to be used. Slip type fittings shall not be used.
7. For outdoor service terminations with a direct burial lateral, the horizontal portion of the conduit shall extend through a minimum of 12" of undisturbed earth where practical, defined as follows:
 - a. Undisturbed earth: The area not excavated for the construction of the building (may be compacted fill).
 - b. Fill area: The area between the building wall and the undisturbed earth (may vary from a few inches to several feet or more).
8. Underground services shall require a minimum 6' wide path of clearance.
9. Refer to outlet location letter and/or signed sketches for services that may have concrete encased laterals.
10. Excess service entrance conductor slack is not allowed to be "lost" in the service entrance equipment.

Grounding

1. Grounding shall be in accordance with all applicable codes.
2. The grounding electrode conductor shall not be run through the meter pedestals, transockets, or termination compartment, unless a separate raceway is provided. **Raceway shall not be installed inside service equipment.** The grounding electrode conductor may terminate on the neutral bus of: the termination compartment for multi-metered installations provided it does not interfere with the installation of the service lateral conductors or a meter pedestal equipped with a main disconnect and listed as Service Equipment.
3. Ground rods and grounding electrode conductors shall not be located in front of meter pedestals or raceways.
4. Bonding to other systems(ex: communication) shall not be done on/within a metering enclosure unless a means of bonding intended for inter-system bonding is furnished as part of the metering enclosure (PSC 114.099(C)).

Metering

1. This section details the requirements for underground service lateral terminations and connections. Refer to the metering section of this manual for details of the metering requirements for each installation.

REFERENCE

NAME OF PARTS FOR UNDERGROUND SERVICE

Customer furnishes and installs:

- A - Meter pedestal
- B - Service entrance conduit and conductors
- C - Distribution panel, main fuse/disconnect
- D - Transocket
- E - Transformer rated meter socket
- F - Wiring trough (1600 Amp maximum)
- G - Termination compartment, either wire or bus connected type.
- H - Metering or main disconnect/fuse, wire connected for use with wire type termination compartment only.

Customer furnishes and installs:

- I - Metering equipment, bus connected for use with bus connection type termination compartment only and of same manufacturer.
- J - Service lateral conduit

Company furnishes and installs:

- K - Underground service lateral
- L - Watthour meter

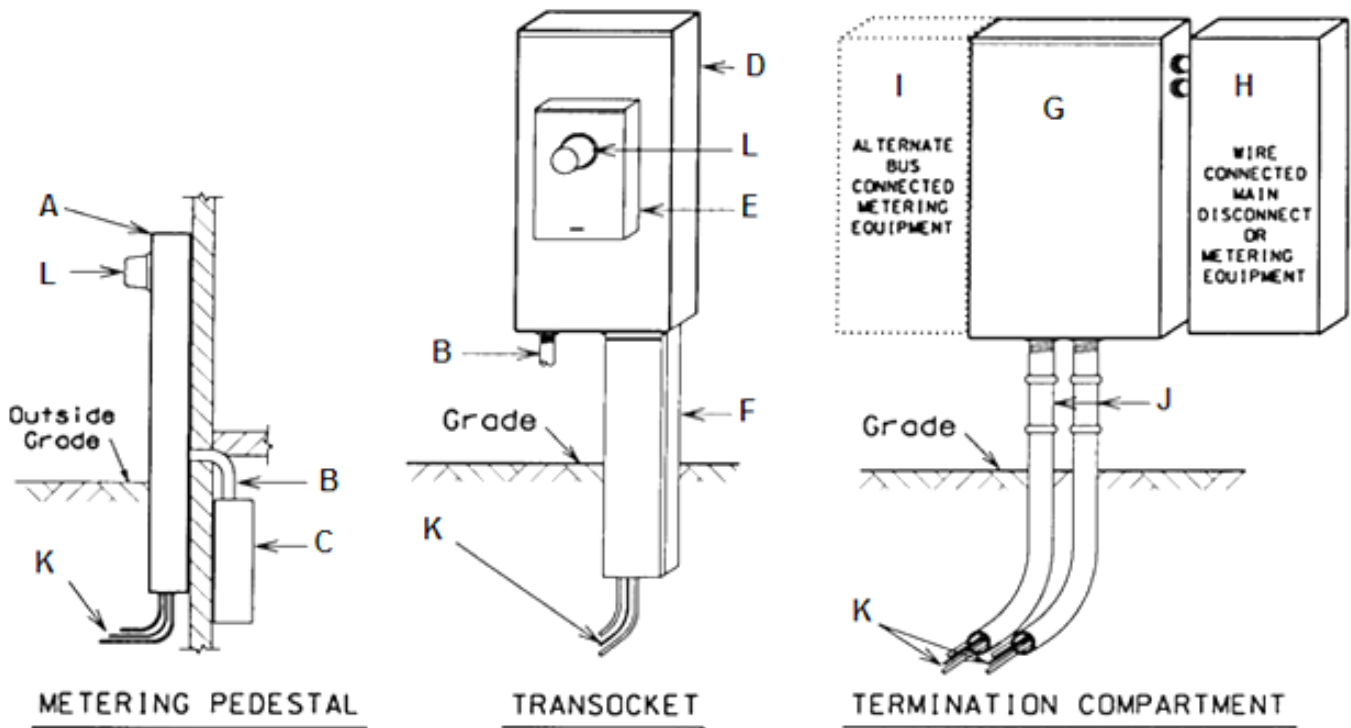

TYPICAL NUMBER AND SIZE OF SERVICE LATERAL CONDUITS INSTALLED

Service Size	Number of Conduits	Size of Conduits	Number of Conduit Sweeps	Size of Conduit Sweeps (radius)
400A	1	4"	1	36"
600A	2*	4"	2	36"
800A	2	4"	2	36"
1200A	3	4"	3	36"
1600A	4	4"	4	36"
2000A	6	4"	6	36"
3000A	8	4"	8	36"
4000A	10	4"	10	36"

Note: See page U-4 for conduit layouts.

***If 1-750 is used then only one conduit is needed**

REFERENCE

CONDUIT LAYOUTS

For indoor gear, customer furnishes and installs:

1. Service lateral conduit.
2. Steel reinforcing rods, 5/8" x 6' (epoxy coated re-bar).
3. Conduit spacers.
4. Continuous concrete envelope with a minimum of 3" of concrete on all sides.

Notes:

1. The grounding electrode conductor shall not be run through the meter pedestals, transockets, or termination compartment, unless a separate raceway is provided.
2. A concrete encased service lateral is provided for 3000A and larger services, areas fed by the conduit and manhole system, and as needed for mechanical protection or ampacity concerns.
3. For non-concrete encased service laterals, the company's conduit service lateral will be installed in the same configurations as shown.

Conduit Details for 400 – 1600 Amperes

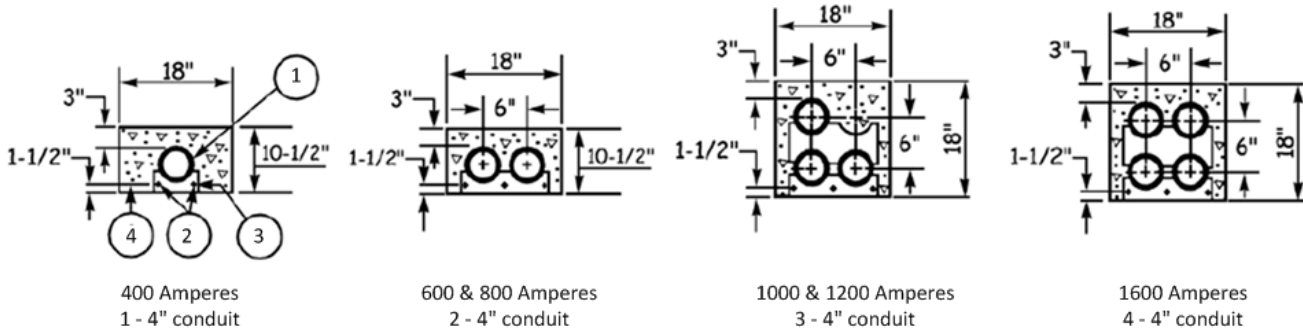

Conduit Details for 2000 – 4000 Amperes

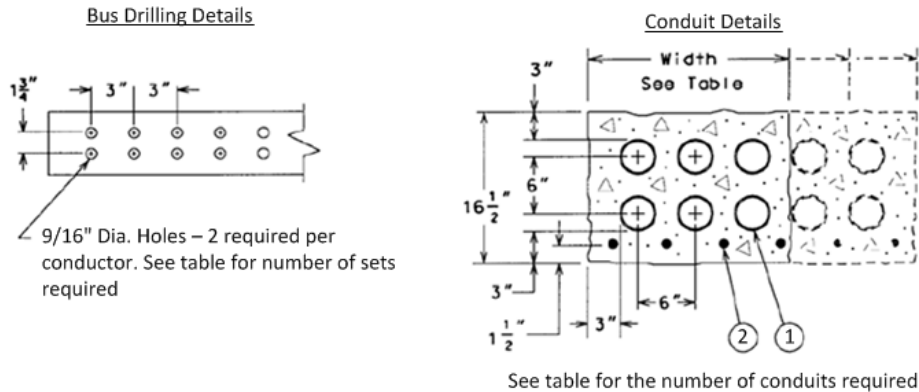

Switchgear Requirements 2000, 3000, and 4000 Amperes				
Switchgear Amperage	Minimum Width of Termination Compartment	Sets of Holes Required	Minimum Number of Ducts	Width of Conduit Package
2000	24 Inches	6	6	24 Inches
3000	30 Inches	8	8	30 Inches
4000	36 Inches	10	10	36 Inches

Note: The dimensions shown above are minimums and should not be used for design purposes. For actual dimensions contact the switchgear manufacturer.

Note: For switchgear, the conduit shall be installed so the duct package width is parallel with the bus.

SERVICE TERMINATION IN A SERVICE ASSEMBLY FOR MOBILE HOMES

1 OR 2 METERS, 1Ø, 120/240 VOLT, 0-200A PER METER

Customer furnishes and installs:

1. Company listed mobile home metering pedestal (see D-11).
2. Company listed pedestal supporting stake bolted to the pedestal (see D-9) or equivalent (see Note 1).
3. Grounding electrode conductor in non-metallic conduit and grounding electrode(s) per applicable codes (see U-2).

Company furnishes and installs:

4. Watthour meter.
5. Service lateral (radial feed, loop through installation)

Notes:

1. A 1-5/8" x 1-5/8" galvanized steel framing channel 80" long or a galvanized steel support or equal strength.
2. Article 550 of the *National Electric Code* covers the special requirements for mobile homes. A few of the requirements are listed below. See the NEC for a complete listing of the requirements.
 - Mobile home service equipment must have a means for providing service to an auxiliary building or electrical equipment located outside the mobile home by a fixed wiring means.
 - Additional 120 Volt, 15 or 20 Amp GFCI protected receptacles are permitted for equipment located outside of the mobile home.
 - The service or disconnecting means must be within sight of and not more than 30 feet from an exterior wall of the mobile home.
 - All wiring must be installed as per the NEC, State, and Local ordinances.

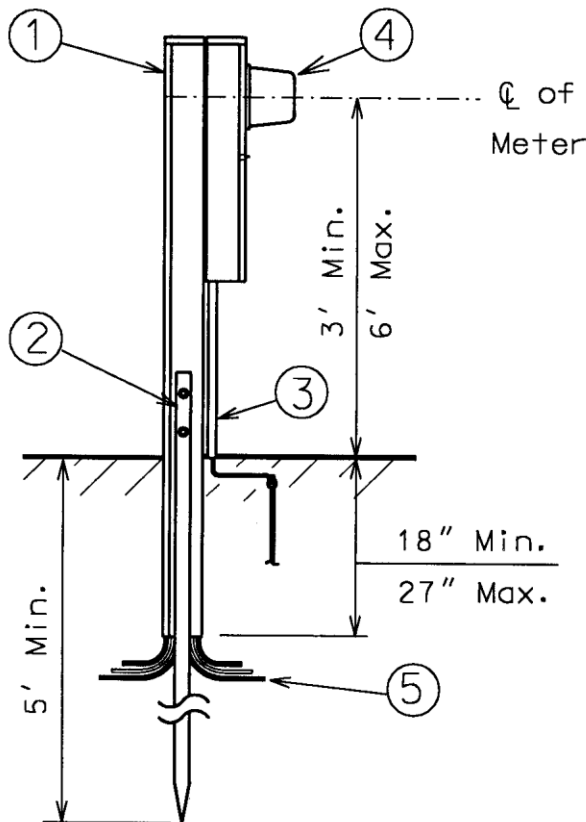

SIDE VIEW of SINGLE METER UNIT

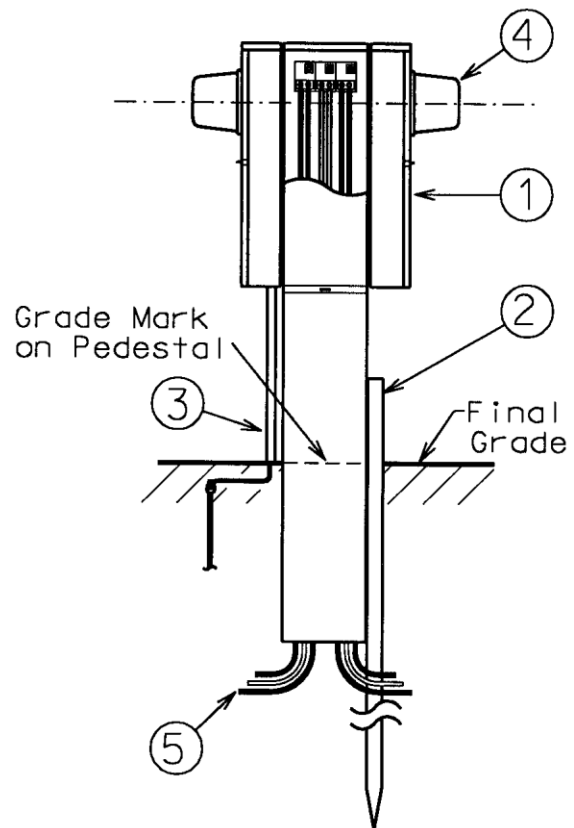

SIDE VIEW OF DOUBLE METER UNIT SHOWING SERVICE LATERAL TERMINATIONS

SERVICE TERMINATION IN A METER PEDESTAL, DIRECT BURIED LATERAL (0-320A)

FREE STANDING, 1 METER NOT TO BE USED FOR MOBILE HOMES

Customer furnishes and installs:

1. Company listed meter pedestal (see Notes 1).
2. Company listed supporting stake or concrete footing (.75 cubic feet minimum) (see Notes 2 & 3 and D-9)
3. Service entrance conductors (not shown, see Note 4).
4. Service entrance conduit.
5. Ground conductor in non-metallic conduit, installed only when the pedestal has a main disconnect.
6. Grounding electrode(s) per applicable codes (see U-2).
7. Accessory foot for concrete foundations.

Company furnishes and installs:

8. Service lateral.
9. Watthour meter.

Notes:

1. Unit shall have a main service switch and fuse, or circuit breaker, either integral or attached to the pedestal.
2. Pedestal shall be set in firmly compacted soil up to the grade line of the pedestal.
3. A 1-5/8" x 1-5/8" galvanized steel framing channel 80" long or a galvanized steel support of equivalent strength.
4. Service entrance conductors shall exit the pedestal below the lowest live part and above grade.

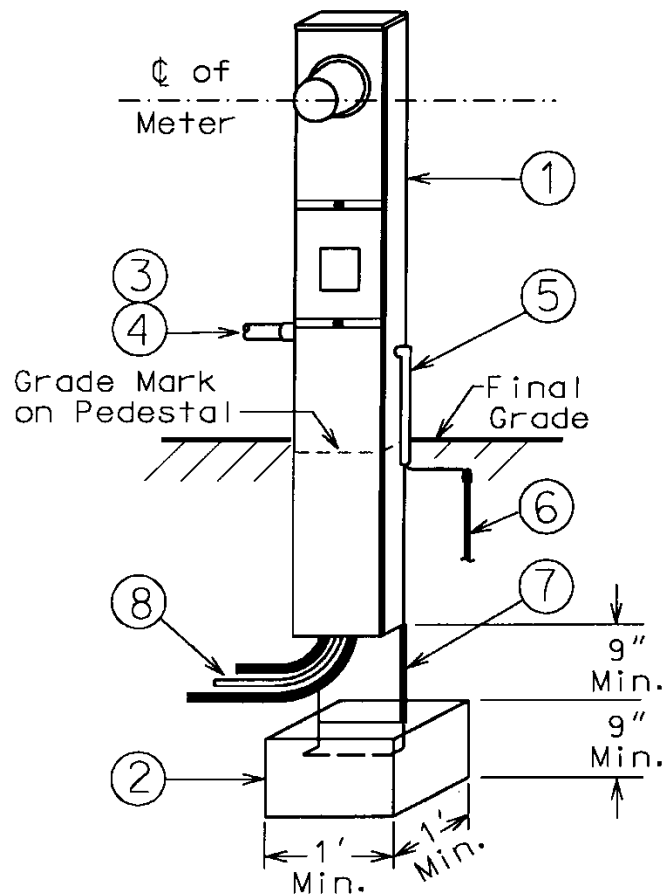
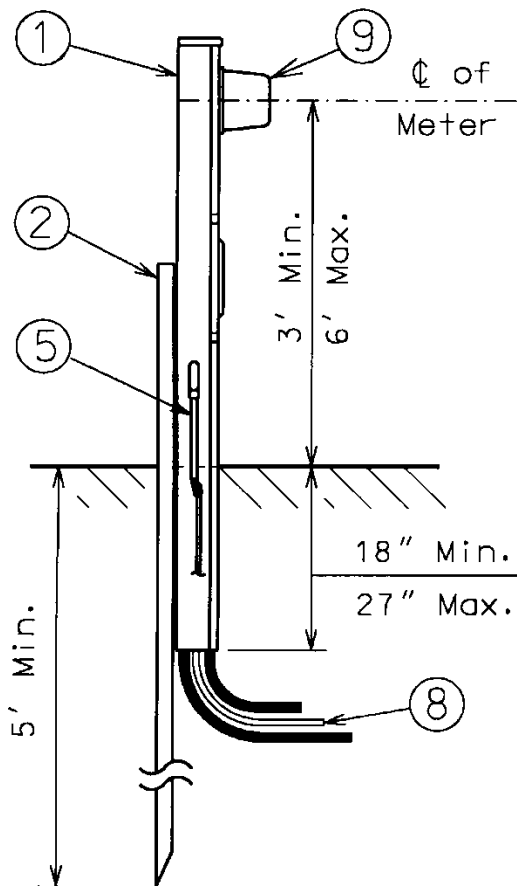

SERVICE TERMINATION IN A METER PEDESTAL, DIRECT BURIED LATERAL (0-320A) ATTACHED TO A BUILDING

Customer furnishes and installs:

1. Company listed meter pedestal (see Notes 1 & 2).
2. Service entrance conduit.
3. Service entrance conductors (not shown, see Note 3).

Company furnishes and provides:

4. Service lateral.
5. Watthour meter.

Notes:

1. Pedestal shall set in firmly compacted soil up to the grade line of the pedestal.
2. The customer shall be responsible for firmly securing the pedestal to the building.
3. Service entrance conductors shall exit the pedestal below the lowest live part and above grade.
4. An allowance for the building wall, when the pedestal is mounted to the foundation, must be present.
5. When a two position meter pedestal is installed, the positions must be labeled (see Note 7 on M-2).

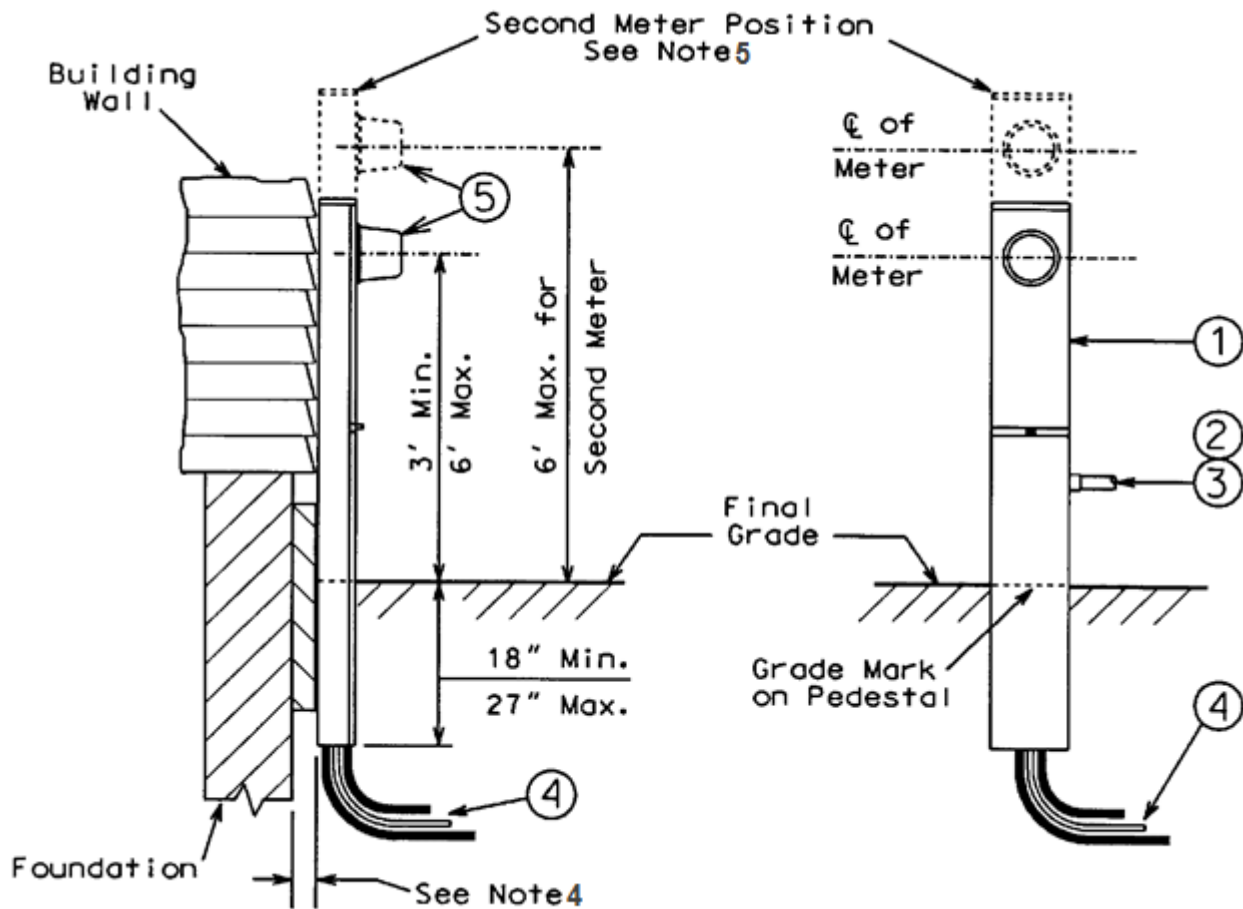

SERVICE TERMINATION IN A MULTI-POSITION METER SOCKET (1Ø, 120/240 VOLTS, 0-400A BUS, 0-200A PER METER, 2-6 METERS)

DIRECT BURIED LATERAL

Customer furnishes and installs:

1. Service entrance conduit.
2. Service entrance conductors.
3. Metallic conduit shall be bonded.
4. Company listed 2 to 6 position meter socket (see all Notes below and D-7, D-8, or D-9).
5. Service lateral wiring raceway.

Company furnishes and installs:

6. Service lateral.
7. Watthour meters (not shown).

Notes:

1. The company will provide lugs for terminating incoming service lateral for all sockets rated 600 Amps or more.
2. Separate cable compartments provided on some meter sockets are for the Company's service lateral cable only.
3. Each meter position shall be marked on the outside of the socket or by the breaker (if available) with the address of the unit served. If the marking is on the outside of the removable cover, it shall also be marked on the inside of the meter socket in a visible location. This marking shall also be placed on the corresponding distribution panel(s). The marking shall be a permanent label with 1/2" block letters and may consist of individual self-stick letters or numbers, suitable for the location so as to be considered permanent (see Note 7 on M-2).

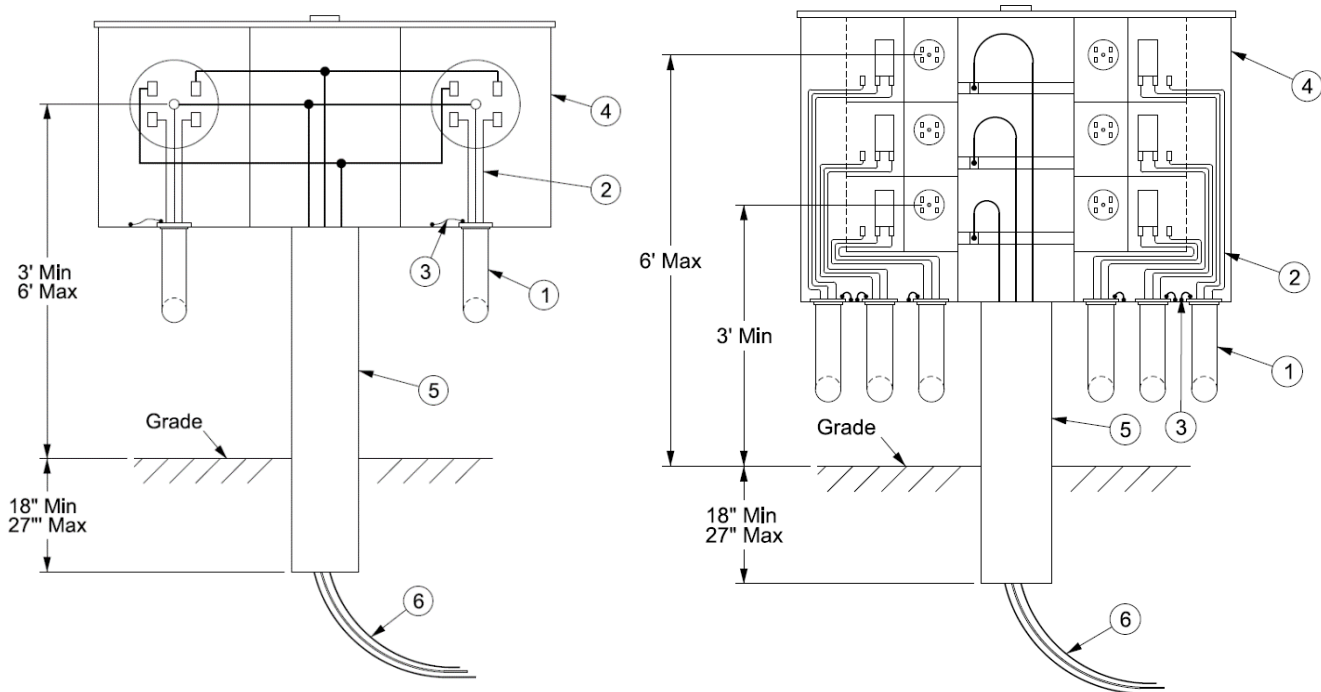

SERVICE TERMINATION IN AN OUTDOOR METER SOCKET

TEMPORARY SERVICE

1Ø, 120/240 VOLTS, 0-200A

1Ø, 120/208 VOLTS, 0-100A

Customer furnishes and installs:

1. Treated 4" x 4" wood post or equivalent (see Note 1).
2. Painted 3/4" weatherproof plywood to extend a minimum of 1" beyond the meter socket on all 4 sides.
3. Company listed 200A meter socket (D-7).
4. Metallic conduit shall be bonded.
5. Service entrance conductors.
6. Service entrance conduit.
7. Weatherproof disconnecting means (see Note 2).
8. Ground conductor in conduit.
9. Grounding electrode(s) per applicable codes (see U-2).
10. Service lateral conduit (see Note 3).
11. Split ring type conduit supports or galvanized steel 2-hole conduit straps.
12. 2" 90° elbow (see Note 3).

12. 2" 90° elbow (see Note 3).

Company furnishes and installs:

13. Service lateral.
14. Watthour meter (not shown).

Notes:

1. The temporary service assembly shall be located 6' from the Company service pedestal or padmounted transformer.
2. Consult the local Company office for alternate locations for mounting the disconnect.
3. 2" galvanized rigid, galvanized intermediate, or rigid non-metallic sch. 80 PVC conduit per NEMA standard TC-2.
4. For larger C.T. rated temporary services, see freestanding & temporary transockets, U-10.

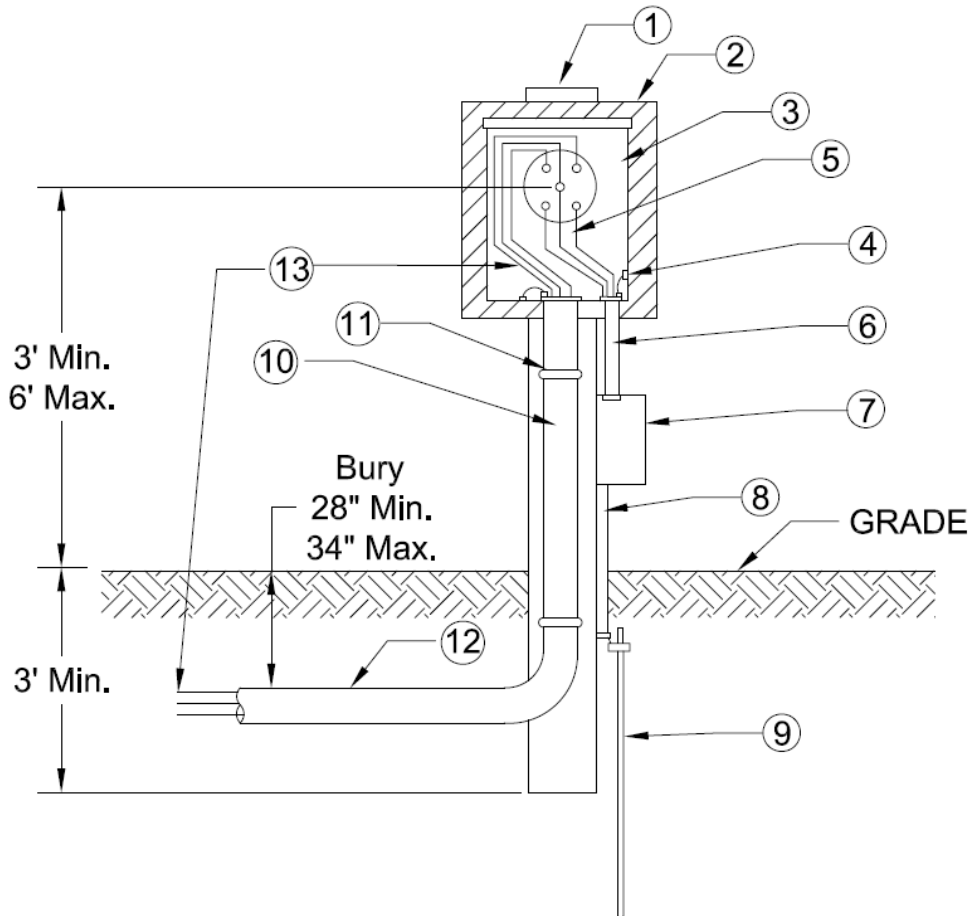

SERVICE TERMINATION IN A TRANSOCKET

FREESTANDING & TEMPORARY SERVICE

1Ø, 120/240 VOLTS, 400-800A

ALL 3Ø VOLTAGES, 400-3000A

Obtain accept for 1Ø installations larger than 400A from the Company

Customer furnishes and installs:

1. Company listed transocket (see M-17 & D-15).
2. Company listed transformer rated meter socket, supplied with transockets (see D-17).
3. Service lateral conduit (Raceway preferred see Notes 1, 2, & 3).
4. 4" galvanized rigid or IMC 90° elbow with 24" radius.
5. Insulated conduit bushing (see Note 4).
6. Service entrance conduit.
7. Galvanized steel framing channel, 1-5/8" x 1-5/8" x 12 Ga.
8. Two conduit supports solidly attached to frame (above grade).
9. 3" galvanized rigid with galvanized end cap (see Note 5).
10. Concrete footing (12" min. hole size).

Company furnishes and installs:

11. Service lateral with compression lug terminations (600A +).
12. Watthour meter, current transformers, & associated meter wiring.

Notes:

1. Galvanized rigid or galvanized intermediate conduit with threaded ends and threaded fittings at the transocket are required. Metallic conduit shall be bonded. Reference page U-3 for the proper number and size of the conduits and U-4 for conduit details. Contact the We Energies job representative for approval.
2. Conduits to be grouped at end furthest from the termination compartment to allow for service lateral bending.
3. For 400-1600 Amp services, a Company listed cable raceway is preferred (shown as dashed line below). The cable raceway can be used in place of Item 3 above (see D-16).
4. Service lateral conduit shall have a temporary waterproof end cap to prevent the accumulation of water, ice, and other foreign matter from inside the conduit.
5. As an alternative to Item 9 above, 4" x 4" x 3/8" galvanized steel angle may be used.
6. For concrete encased service lateral, refer to U-12, U-20/21, and U-22/23.
7. Temporary services may also be constructed out of wood, refer to U-11.

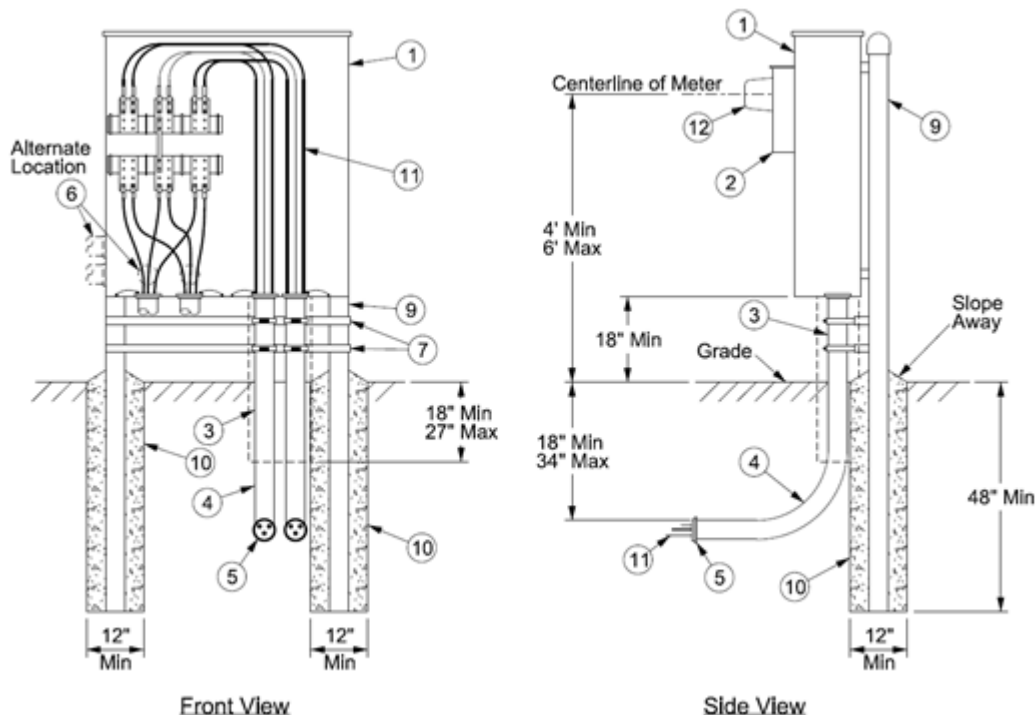

Single phase, 3-wire transocket shown.

SERVICE TERMINATION IN A TRANSOCKET

FREESTANDING FOR FARM SERVICES ONLY

1Ø, 120/240 VOLTS, 400-800A

Obtain acceptance for 1Ø installations larger than 400A from the Company

Freestanding Wood Frame may be used for Temporary Services, refer to Page U-10 for service size

Customer furnishes and installs:

1. Company listed transocket (see M-17 & D-15).
2. Company listed transformer rated meter socket, supplied with transocket (see D-17).
3. Service lateral conduit (see Notes 1, 2, & 3).
4. 4" galvanized rigid or IMC 90° elbow with 24" radius.
5. Insulated conduit bushing (see Note 4).
6. Service entrance conduit.
7. Galvanized steel framing channel, 1-5/8" x 1-5/8" x 12 Ga.
8. Two conduit supports solidly attached to frame (above grade).
9. Post, 6" x 6", pressure treated for ground contact (preservative retention of .60 # per cu. ft.)
10. Wood, 2X, pressure treated for above ground use (preservative retention of .40 # per cu. ft.)
11. Concrete footing (12" min. hole size).

Company installs and furnishes:

12. Service lateral with compression lug terminations (600A +).
13. Watthour meter, current transformers, & associated meter wiring.

Notes:

1. Galvanized rigid or galvanized intermediate conduit with threaded ends and threaded fittings at the transocket are required. Metallic conduit shall be bonded. Reference page U-3 for the proper number and size of the conduits and U-4 for conduit details. Contact the We Energies job representative for approval.
2. Conduit to be group at end furthest from the termination compartment to allow for service lateral bending
3. For 1Ø 400 – 800A services, a Company listed cable raceway is preferred. The cable raceway can be used in place of Item 3 above (see D-16 for approved raceways). Raceways shall extend 18" to 27" below final grade.
4. Service lateral conduit shall have a temporary waterproof end cap to prevent the accumulation of water, ice, and other foreign matter from inside the conduit.
5. Plywood, Particleboard, or OSB are not acceptable for use with this structure. Only 2X shall be used.

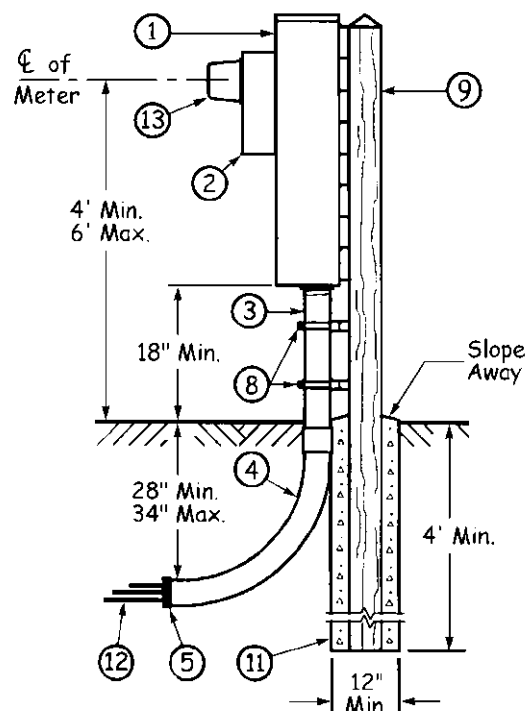
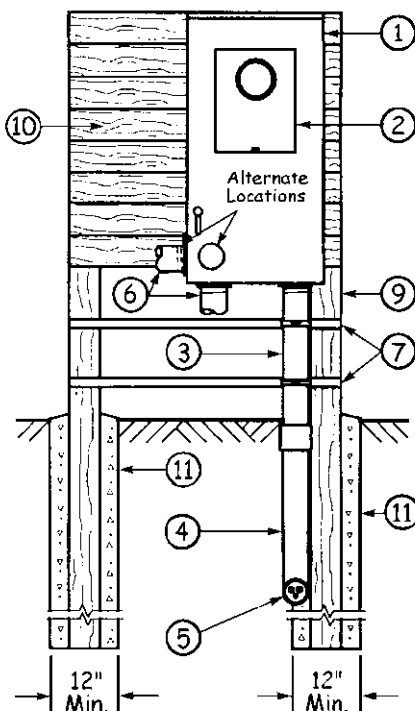

SERVICE TERMINATION IN A TRANSOCKET

OUTDOOR CONCRETE ENCASED LATERAL

1Ø, 120/240 VOLTS, 400-800A

ALL 3Ø VOLTAGES, 400-4000A

Obtain acceptance for 1Ø installations larger than 400A from the Company

Customer furnishes and installs:

1. Company listed transocket (see M-17, D-15, & Note 1).
2. Company listed transformer rated meter socket, supplied with transocket (see D-17).
3. Service entrance conduit and conductors.
4. Metallic conduit shall be bonded.
5. Raceway, preferred, 1600A Maximum (see D-16).
6. Service lateral conduit (see Notes 2 & 3).
7. Two conduit supports solidly attached to building (above grade).
8. Solid bar.

Company furnishes and installs:

9. Service lateral conduit and concrete envelope.
10. Service lateral with compression lug terminations (600A+).
11. Watthour meter, current transformers, & associated meter wiring.

Notes:

1. The cable trough compartment (for 400-4000A services) is for the Company's service lateral cables only. This compartment may be on the left side, contact your manufacturer or distributor.
2. Galvanized rigid or galvanized intermediate conduit with threaded ends and threaded fittings at the transocket are required. Reference page U-3 for the proper number and size of the conduits and U-4 for conduit details. A Company listed cable raceway is the preferred method of installation. The cable raceway can be used in place of Item 4 above (see D-16 for approved raceways). Raceways shall extend 3" to 6" below final grade. Contact the We Energies job representative for approval.
3. Conduits to be grouped at the end furthest from the termination compartment to allow for service lateral bending (see Note 1).

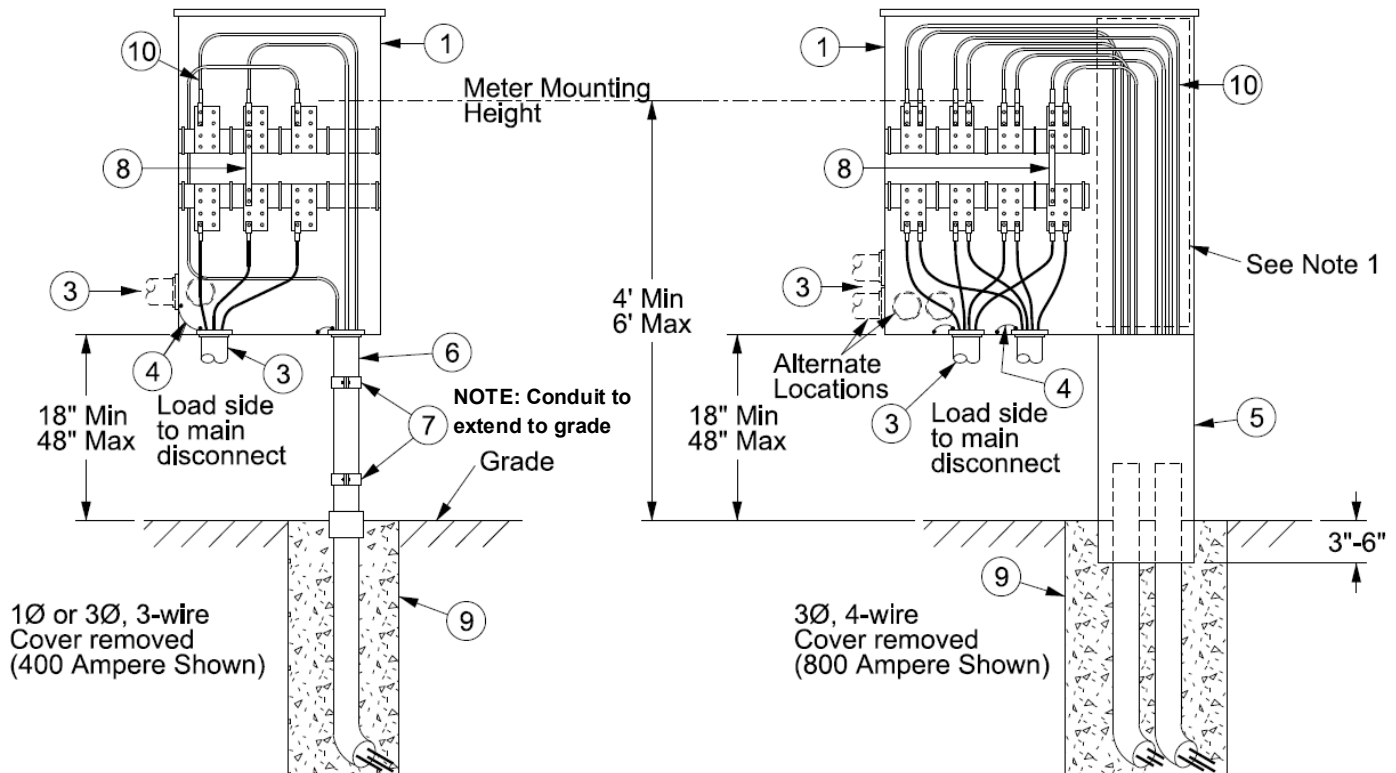

SERVICE TERMINATION IN A TRANSOCKET

OUTDOOR DIRECT BURIED OR DIRECT BURIED CONDUIT LATERAL

1Ø, 120/240 VOLTS, 400-800A

ALL 3Ø VOLTAGES, 400-2000A

Obtain acceptance for 1Ø installations larger than 400A from the Company

Customer furnishes and installs:

1. Company listed transocket (see M-17, D-15 & Note 1).
2. Company listed transformer rated meter socket, supplied with transocket (see D-17).
3. Service entrance conduit and conductors.
4. Metallic conduit shall be bonded.
5. Raceway, preferred, 1600A Maximum (see D-16).
6. Service lateral conduit (see Notes 2 & 3).
7. Two conduit supports solidly attached to building (above grade).
8. Solid bar.

Company furnishes and installs:

9. Service lateral with compression lug terminations (600A +).
10. Watthour meter, current transformers, & associated meter wiring.

Notes:

1. The cable trough compartment (for 400-1200A services) is for the Company's service lateral cables only. This compartment may be on the left side, contact your manufacturer or distributor.
2. Service lateral conduit shall have a temporary waterproof end cap when installed to prevent the accumulation of water, ice, and any other foreign material inside the conduit.
3. Galvanized rigid or galvanized intermediate conduit with threaded ends and threaded fittings at the transocket are required. Reference page U-3 for the proper number and size of the conduits and U-4 for conduit details. A Company listed cable raceway is the preferred method of installation. The cable raceway can be used in place of Item 4 above (see D-16 for approved raceways). Raceways shall extend 18" to 27" below final grade. Contact the We Energies job representative for approval.
4. Conduits to be grouped at the end furthest from the termination compartment to allow for service lateral bending (see Note 1).

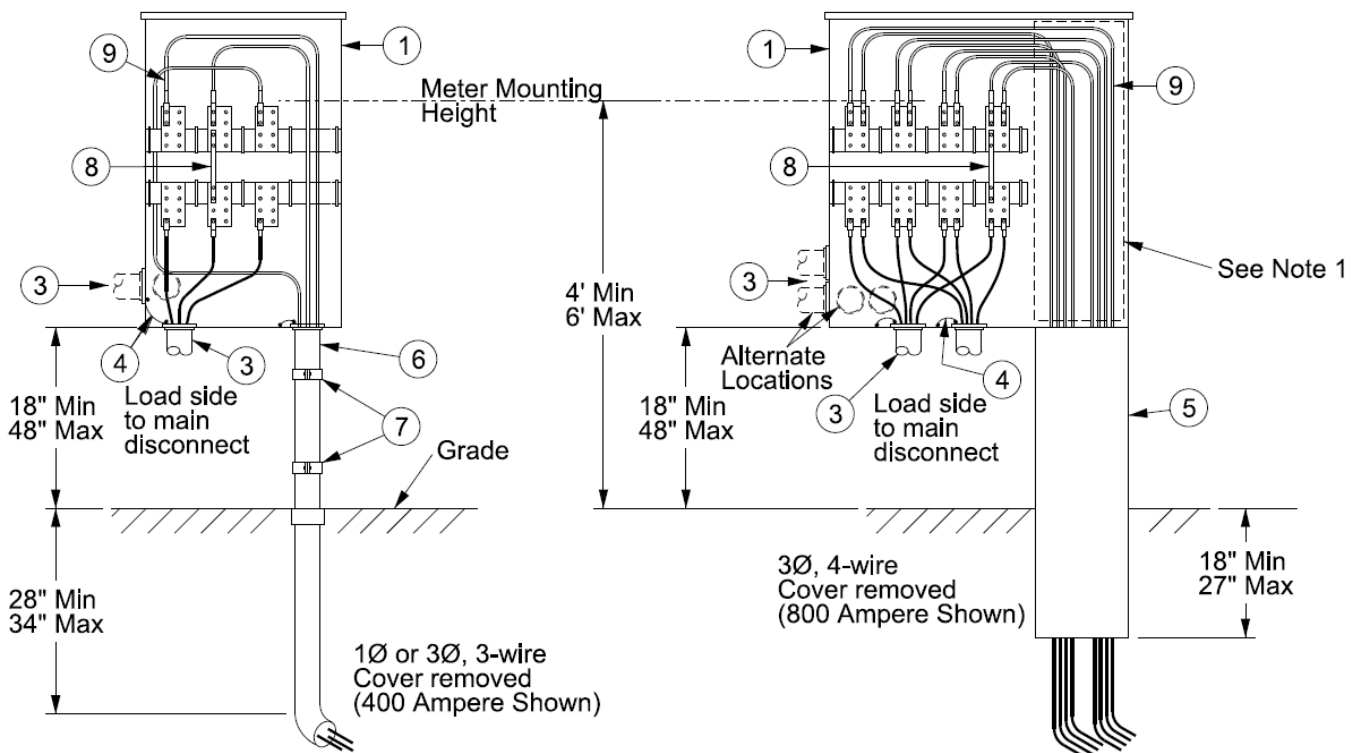

SERVICE TERMINATION IN A TRANSOCKET

PADMOUNTED – BOTTOM ENTRY AND EXIT

ALL 1Ø VOLTAGES, 400-800A

ALL 3Ø VOLTAGES, 400-4000A

Obtain acceptance for 1Ø installations larger than 400A from the Company

Customer furnishes and installs:

1. Company listed transocket (see M-17, D-16 & Note 1).
2. Company listed transformer rated meter socket, supplied with transocket (see D-17).
3. 4" 90° elbow with 36" radius (see Note 1).
4. Insulated conduit bushing (see Note 3).
5. Service entrance conduit.
6. Padmount base (see Note 4).

Company furnishes and installs:

7. Service lateral with compression lug terminations (600A +).
8. Watthour meter, current transformers, & associated meter wiring.
9. Conduit package.

Notes:

1. Schedule 40 PVC, galvanized rigid, or IMC conduit shall extend to be slightly higher than level with the top of the concrete pad (no more than 3" higher). If used, metallic conduit shall be bonded. Reference page U-3 for the proper number and size of the conduits required and U-4 for conduit details. Contact the We Energies job representative for approval.
2. Conduits to be grouped to allow for proper service lateral bending (see Note 1). Only Company cable is allowed in this area.
3. Service lateral conduit shall have a temporary waterproof end cap to prevent the accumulation of water, ice, and other foreign matter from inside the conduit.
4. The concrete pad shall be 6" thick and 3-5" wider and deeper than the transocket.
5. The conduit sweeps shall be oriented to face the transformer. See layout drawing provided by the Company.
6. Knockouts on the bottom of the load side of the rear or back of the enclosure may be used for customer wire.

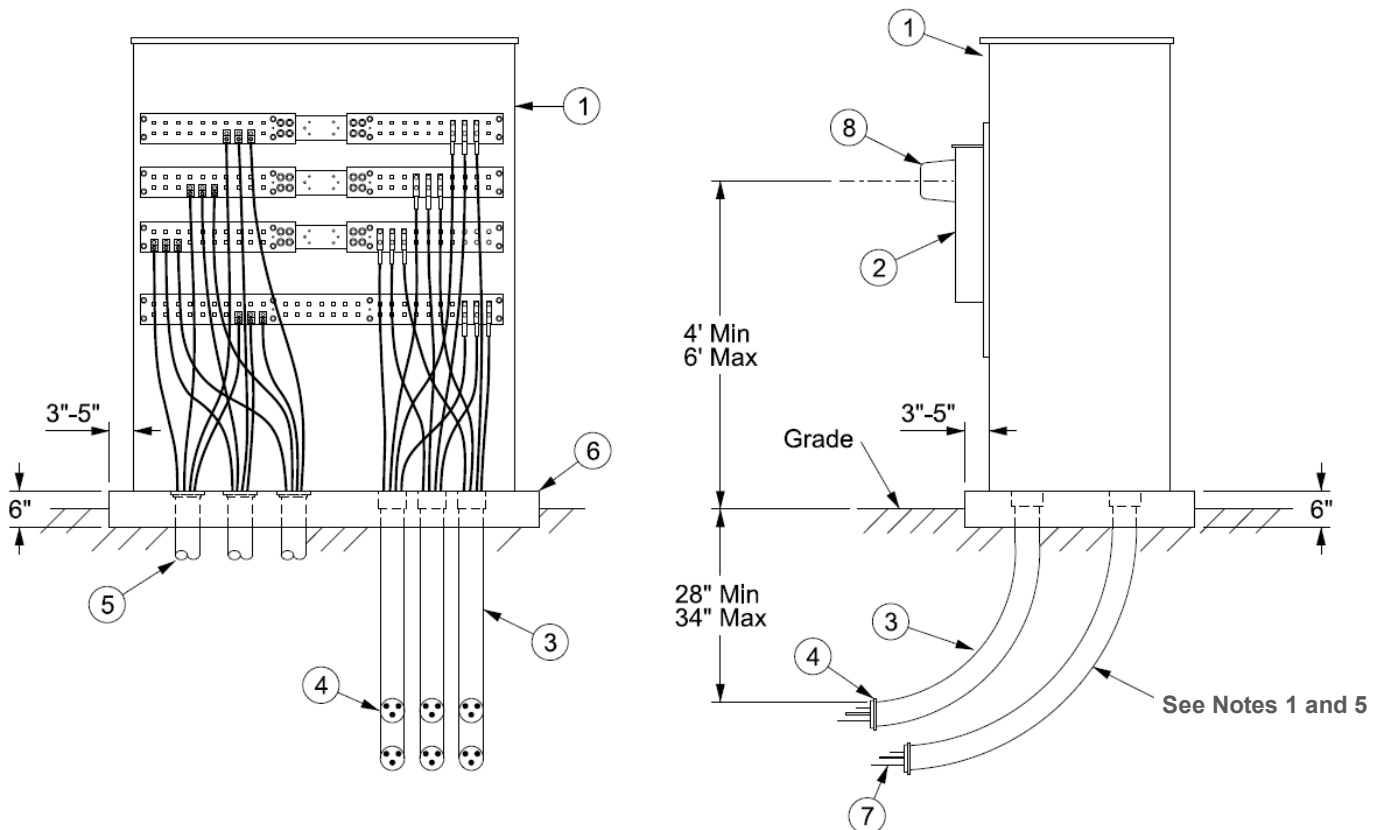

SERVICE TERMINATION IN A TRANSOCKET

FIRST FLOOR INSTALLATION, CONCRETE ENCASED LATERAL

1Ø, 120/240 VOLTS, 400-800A

ALL 3Ø VOLTAGES, 400-3000A

Obtain acceptance from the Company

Customer furnishes and installs:

1. Company listed transocket (see M-17, D-15, & Note 1).
2. Company listed transformer rated meter socket, supplied with transocket (see D-17).
3. Service lateral conduit (see Note 2).
4. Continuous concrete envelope with 3" of concrete on all sides (see Note 2).
5. 4" I.D. 90° bend with 36" minimum radius (see Note 2).
6. Steel reinforcing rods, 5/8" x 2'.
7. Insulated bushing & temporary watertight end cap.
8. Solid bar.

Company furnishes and installs:

9. Service lateral with compression terminations (600A +), conduit, coupling, & concrete envelope.
10. Watthour meter, current transformers, & associated meter wiring.

Notes:

1. The cable trough compartment (for 400-1200A services) is for the Company's service lateral cables only. This compartment may be on the left side, contact your manufacturer or distributor.
2. Galvanized rigid or galvanized intermediate conduit with threaded ends, or rigid nonmetallic schedule 40 PVC is acceptable. Reference page U-3 for the proper number and size of the conduits required and U-4 for conduit details. Contact the We Energies job representative for approval.
3. The We Energies 8' rule applies to all indoor service installations. See Note 3 on U-2 for details.

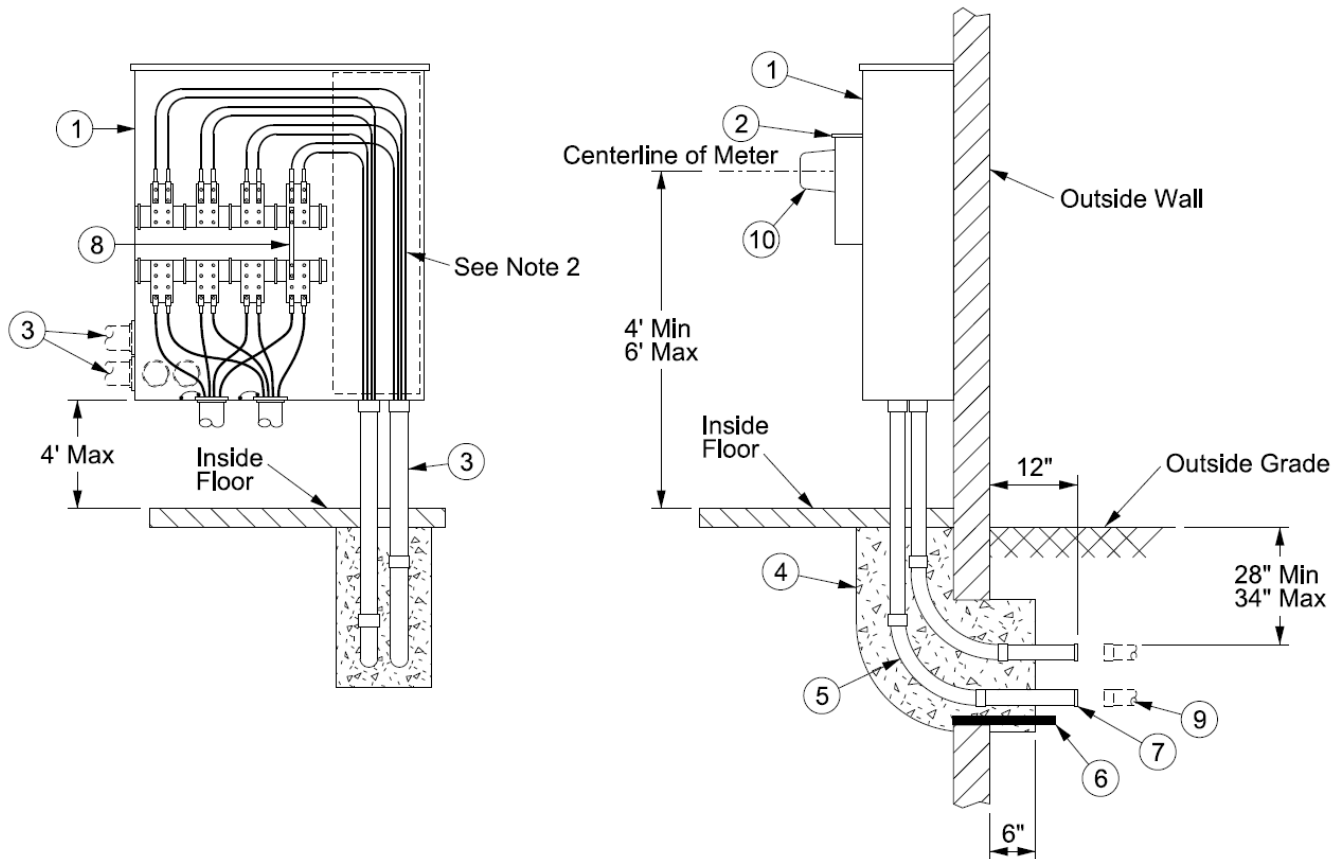

SERVICE TERMINATION IN A TRANSOCKET

FIRST FLOOR INSTALLATION, DIRECT BURIED LATERAL

1Ø, 120/240 VOLTS, 400-800A

ALL 3Ø VOLTAGES, 400-2000A

Obtain acceptance from the Company

Customer furnishes and installs:

1. Company listed transocket (see M-17, D-15, & Note 1).
2. Company listed transformer rated meter socket, supplied with transocket (see D-17).
3. Service lateral conduit (see Note 2).
4. Continuous concrete envelope with 3" of concrete on all sides (see Note 2).
5. 4" I.D. 90° bend with 36" minimum radius (see Note 2).
6. Insulated bushing & temporary watertight end cap.

Company furnishes and installs:

7. Watthour meter, current transformers, & associated meter wiring.
8. Service lateral with compression lug terminations (600A +) (not shown).

Notes:

1. The cable trough compartment (for 400-1200A services) is for the Company's service lateral cables only. This compartment may be on the left side, contact your manufacturer or distributor.
2. Galvanized rigid or galvanized intermediate conduit with threaded ends, or rigid nonmetallic schedule 40 PVC is acceptable. Reference page U-3 for the proper number and size of the conduits required and U-4 for conduit details. Contact the We Energies job representative for approval.
3. The We Energies 8' rule applies to all indoor service installations. See Note 3 on U-2 for details.

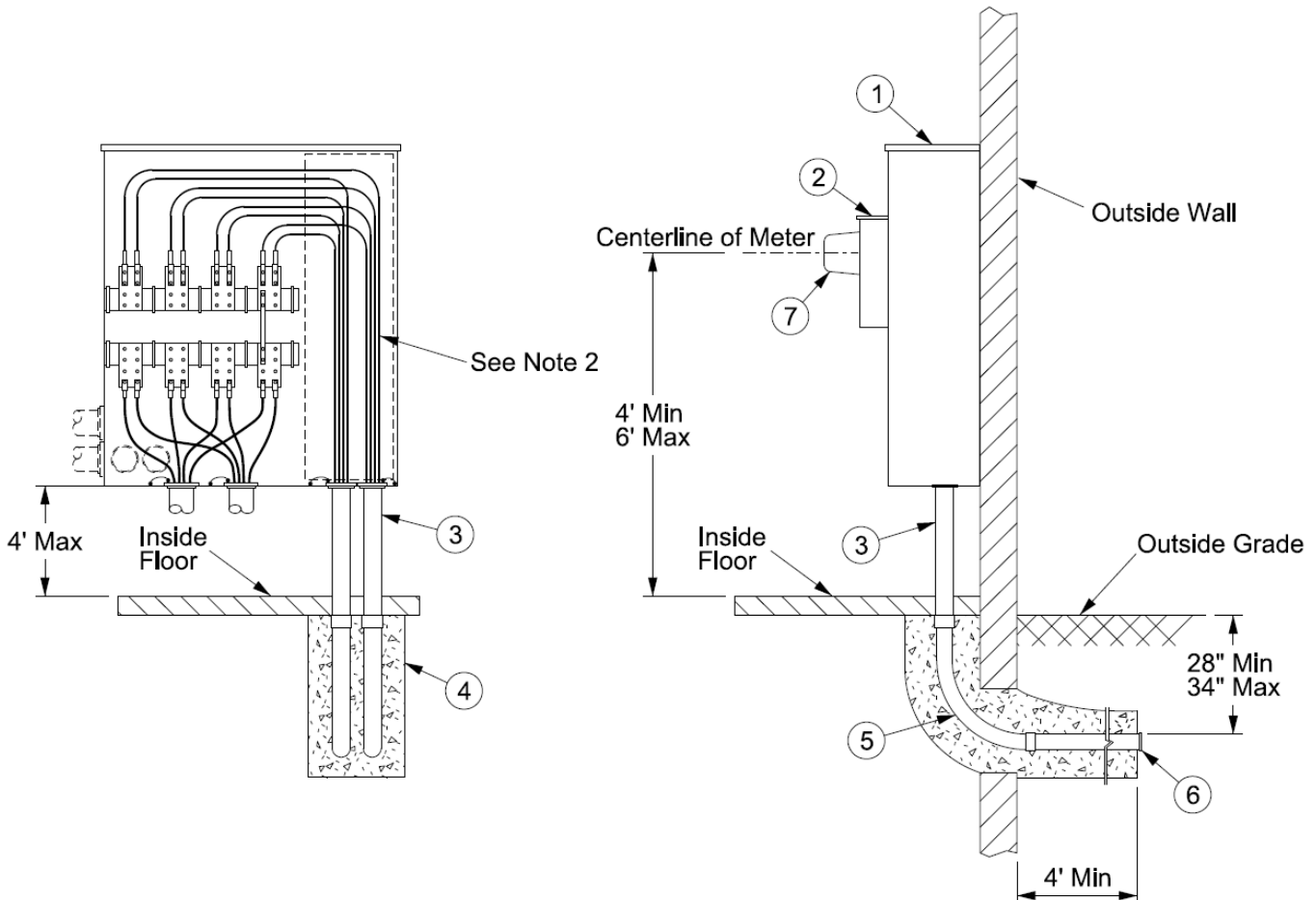

SERVICE TERMINATION IN A TERMINATION COMPARTMENT

GENERAL INFORMATION

Different manufacturers offer bottom entry, bottom exit termination compartments with different termination styles.

- a. Style A: Terminations run perpendicular to the face of the enclosure. The customer uses the rear portion of the terminations and conduits; the front portion of the terminations and conduits shall be reserved for the Company. The drawing below shows an example (with door removed), with the **customer** portion of the conduits and terminations outlined in yellow.

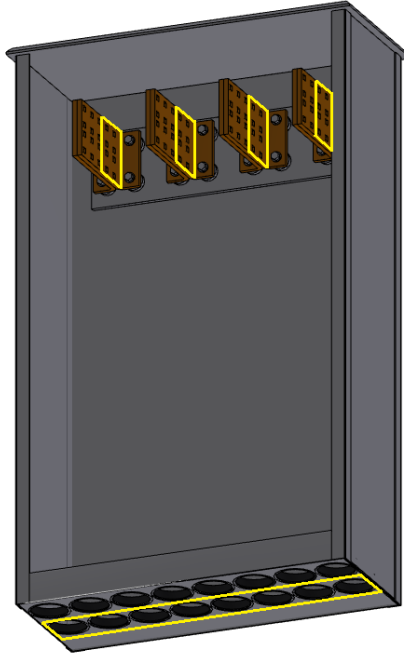

- b. Style B: Terminations run parallel to the face of the enclosure. The customer uses only one side of the terminations and conduits; the company uses the other. Follow the documentation provided by the Company to determine which side to use. The drawing below shows an example (with door removed), with the **customer** portion of the conduits and terminations outlined in yellow (customer designated left side shown).

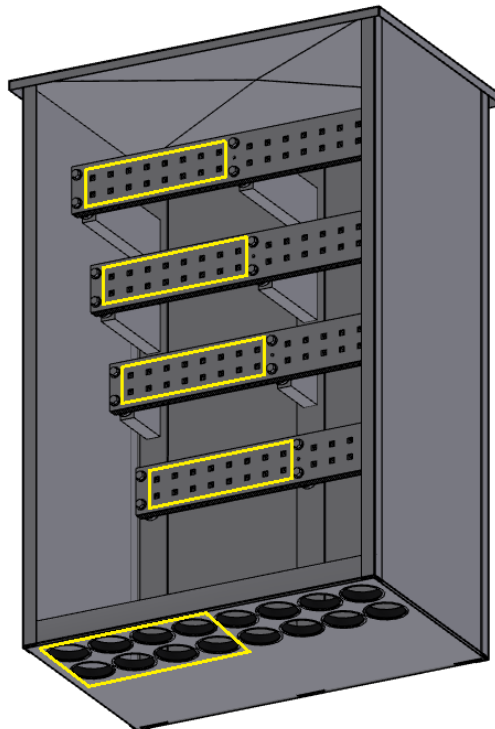

SERVICE TERMINATION IN A TERMINATION COMPARTMENT

ALL OUTDOOR LATERALS ALL 1Ø VOLTAGES, 400-800A ALL 3Ø VOLTAGES, 400-3000A

Obtain acceptance for 1Ø installations larger than 400A from the Company

Customer furnishes and installs:

1. Company listed termination compartment (see Note 1 & D-18).
2. Raceway, 400-1600A max (see Note 2 & D-16).
3. Service lateral conduit, 400-3000A (see Note 3).
4. Conduit supports.
5. Service entrance conduit (see Note 4).
6. Service entrance conductors (see Note 5).
7. Bonding. Metallic conduit shall be bonded.
8. 90° metallic elbow (see Note 6).
9. Insulated conduit bushing.

Company furnishes and installs:

10. Service lateral with compression lug terminations (600A +).
11. Conduit package.

Notes:

1. The termination compartment may be bonded to the neutral termination pad.
2. For either direct buried or concrete encased services 1600A or less, the raceway is preferred (see D-16 for approved raceways). For direct buried service laterals, raceways shall extend 18" to 27" below final grade. For concrete encased service laterals, raceways shall extend 3" to 6" below final grade. If the raceway cannot be used, such as where the termination compartment is located in a paved area, conduit may be used (both shown on next page). Consult We Energies job representative for approval and number of conduits required.
3. Galvanized rigid or galvanized intermediate conduit with threaded ends and threaded fittings at the termination compartment are required.. For concrete encased laterals, the lower ends are not required to be threaded. Conduits are to be located on 6" centers and extend to grade level. Reference page U-3 for the proper number and size of the conduits and U-4 for conduit details. Contact the We Energies job representative for approval.
4. If the service entrance conduits are located above the termination pads, watertight hubs or sealing locknuts are required. When the service entrance conduit enters cabinet at the top, watertight hubs are required.
5. The customer's service entrance conductors shall leave the termination compartment as a maximum of two circuits regardless of the number of conductors per phase.

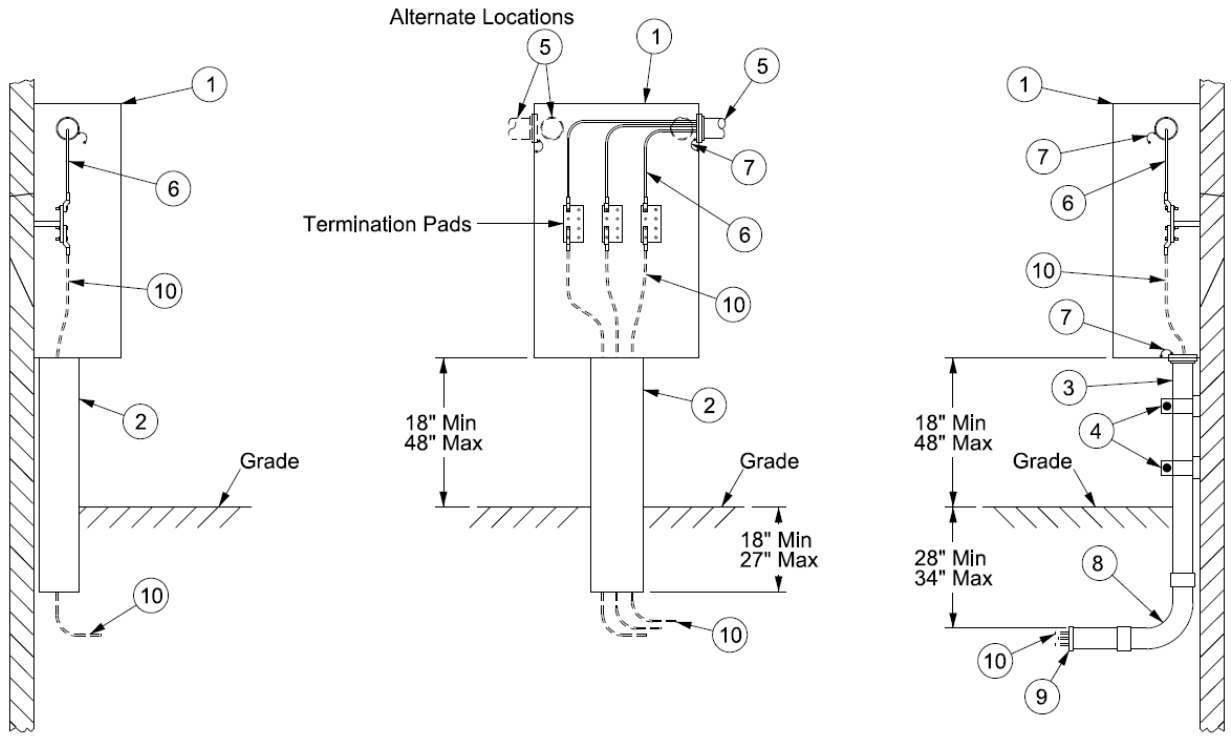

Side View Wireway

Front View Wireway

Side View conduit installation

WITH SERVICE LATERAL DIRECT BURIED IN EARTH

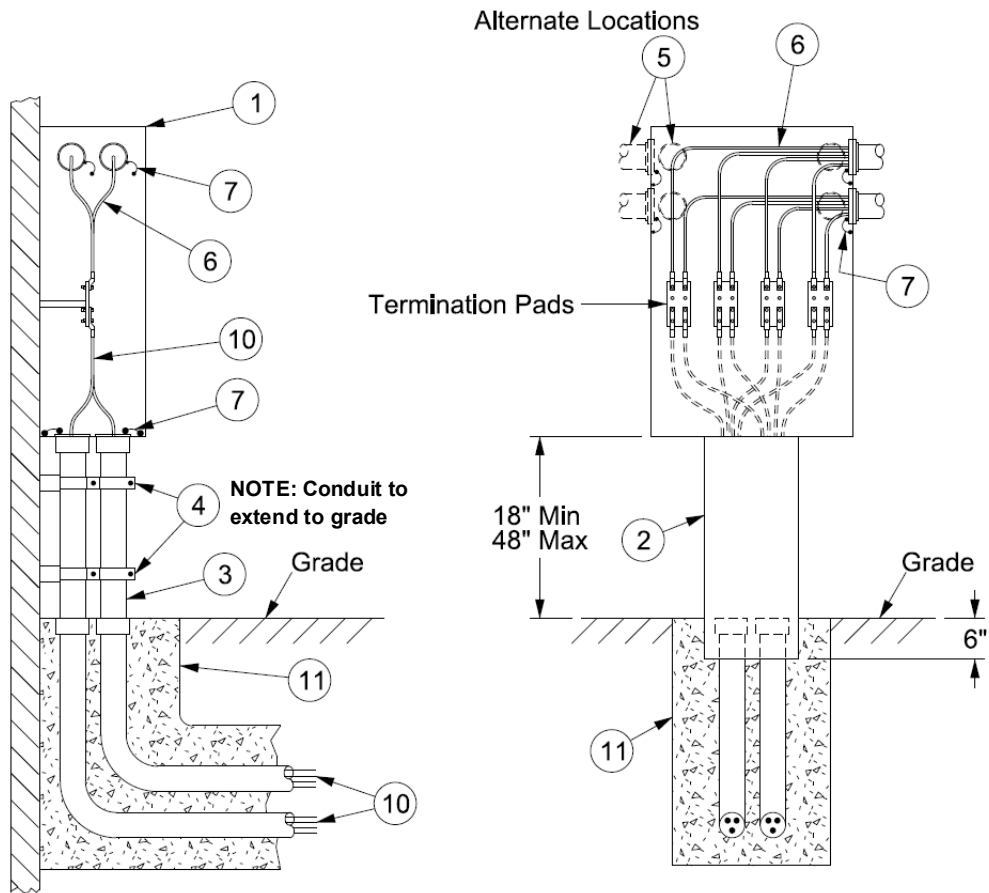

Side View

WITH SERVICE LATERAL IN CONDUIT

SERVICE TERMINATION IN A TERMINATION COMPARTMENT

ABOVE GRADE – BOTTOM ENTRY AND EXIT

ALL 1Ø VOLTAGES, 400-800A

ALL 3Ø VOLTAGES, 400-3000A

Obtain acceptance for 1Ø installations larger than 400A from the Company

Customer furnishes and installs:

1. Company listed termination compartment (see Note 1 & D-19).
2. Termination pads (see Note 2).
3. Service lateral conduit 1200-3000A (see Note 3).
4. Conduit supports, 2 minimum.
5. Service entrance conduit (see Note 4).
6. Service entrance conductors (see Note 5).
7. Bonding. Metallic conduit shall be bonded.
8. 90° metallic elbow (see Note 6).
9. Insulated conduit bushing.

Company furnishes and installs:

10. Service lateral with compression lug terminations (600A +) (see Note 7)
11. Conduit package.

Notes:

1. The termination compartment may be bonded to the neutral termination pad.
2. The termination pads are to be raised to their highest position.
3. Galvanized rigid or galvanized intermediate conduit with threaded ends and threaded fittings at the termination compartment are required.. For concrete encased laterals, the lower ends are not required to be threaded. Conduits are to be located on 6" centers, in the front of the compartment, and extend to grade level. Reference page U-3 for the proper number and size of the conduits and U-4 for conduit details. Contact the We Energies job representative for approval.
4. The customer service entrance conduits shall be located as shown on U-17 for the style of termination compartment used. The Company service lateral conductors are to terminate on the termination pads as per U-17.
5. The customer's service entrance conductors are to terminate on the termination pads as per U-17 and shall leave the termination compartment as a maximum of two circuits, regardless of the number of conductors per phase. They shall not share bolts with the service lateral.
6. The ends of the galvanized rigid or galvanized intermediate 90° metallic elbows shall be threaded and threaded couplings are to be used.
7. Raceways are not to be used with the bottom entry and exit style of installation.

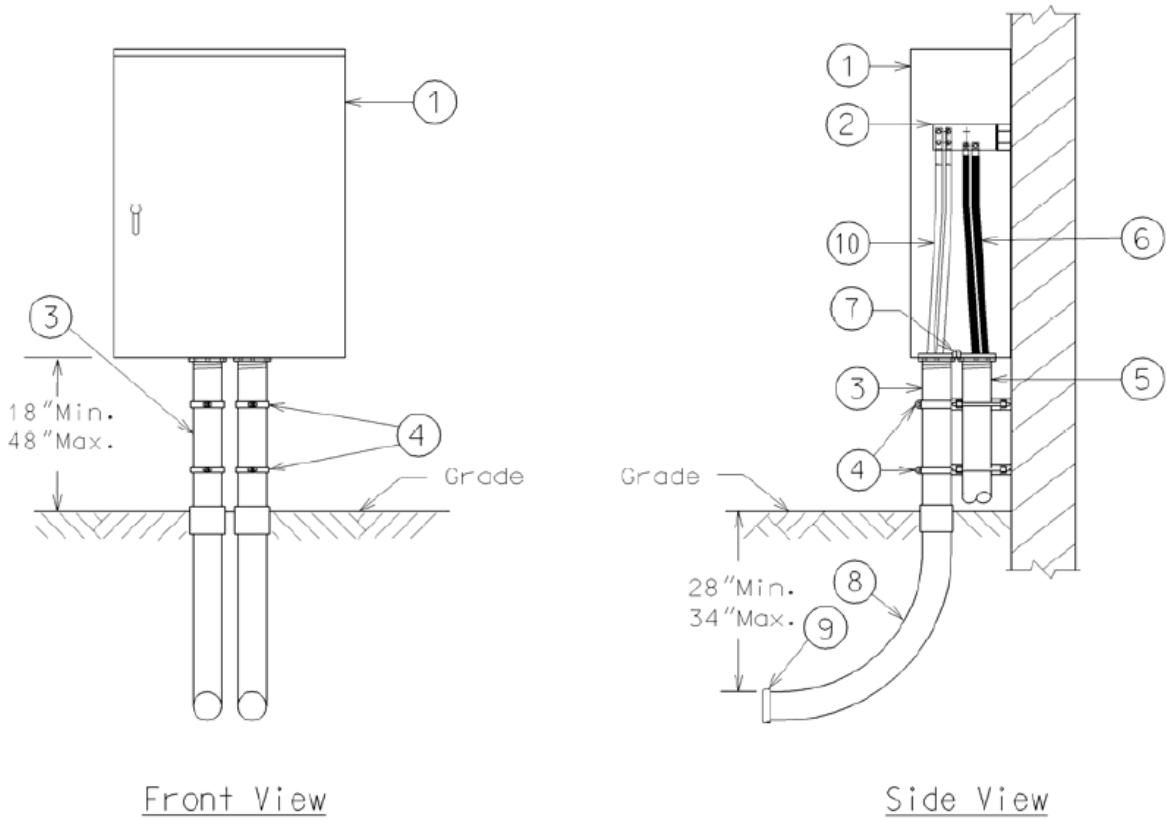

WITH DIRECT BURIED SERVICE LATERAL

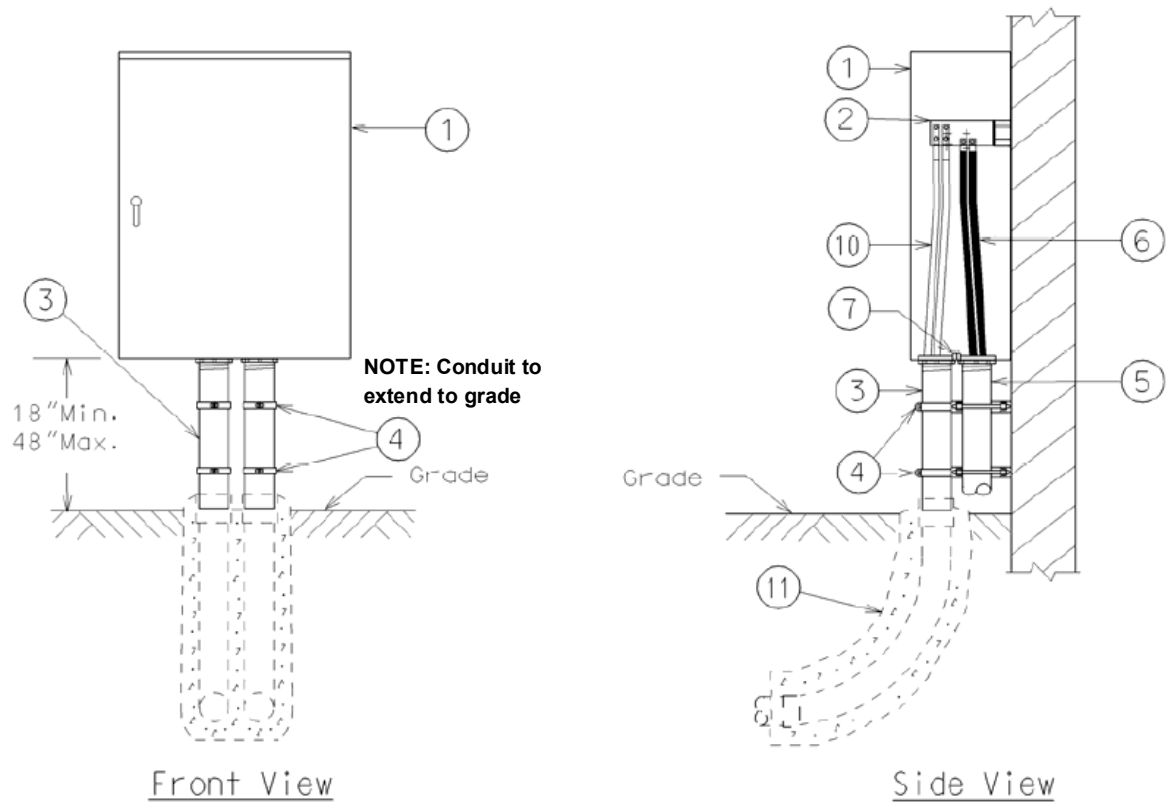

WITH CONCRETE ENCASED SERVICE LATERAL

SERVICE TERMINATION IN A TERMINATION COMPARTMENT

FREE STANDING – BOTTOM ENTRY AND EXIT

ALL 1Ø VOLTAGES, 400-800A

ALL 3Ø VOLTAGES, 400-3000A

Obtain acceptance for 1Ø installations larger than 400A from the Company

Customer furnishes and installs:

1. Company listed termination compartment (see Note 1 & D-19).
2. Termination pads (see Note 2).
3. Service lateral conduit 1200-3000A (see Note 3).
4. Conduit supports, 2 minimum.
5. 90° metallic elbow, 36" radius (see Note 6).
6. Service entrance conduit (see Note 4).
7. Service entrance conductor (see Note 5).
8. Bonding. Metallic conduit shall be bonded.
9. Insulated conduit bushing.
10. Structure supports (see Notes 8, 9 & 10).
11. Concrete footing, 2" min. diameter.
12. Galvanized steel framing channel, 1-5/8" x 1-5/8" x 12 Ga.

Company furnishes and provides:

13. Service lateral with compression lug terminations (600A +) (see Note 7).
14. Conduit package.

Notes:

1. The termination compartment may be bonded to the neutral termination pad.
2. The termination pads are to be raised to their highest position.
3. Galvanized rigid or galvanized intermediate conduit with threaded ends and threaded fittings at the termination compartment are required.. For concrete encased laterals, the lower ends are not required to be threaded. Conduits are to be located on 6" centers, at the front of the compartment, and extend to grade level. Reference page U-3 for the proper number and size of the conduits and U-4 for conduit details. Contact the We Energies job representative for approval.
4. The customer service entrance conduits shall be located as shown on U-17 for the style of termination compartment used. The Company service lateral conductors are to terminate on the termination pads as per U-17.
5. The customer's service entrance conductors are to terminate on the termination pads as per U-17 and shall leave the termination compartment as a maximum of two circuits, regardless of the number of conductors per phase. They shall not share bolts with the service lateral.
6. The ends of the galvanized rigid or galvanized intermediate 90°, 36" radius, metallic elbows shall be threaded and threaded couplings are to be used.
7. To prevent water from entering the structure supports, they must be either capped or filled with concrete.
8. The supports must be spaced far enough apart to allow the service entrance conduits to pass between them. To calculate the minimum distance needed between the supports (center to center) use the formula $(6 \times n) + d$. Where "n" is the number of conduits and "d" is the diameter of the footings.
9. For 400 – 1600 A services, use 3" galvanized rigid conduit supports. For 2000 – 3000 A services, use 4" rigid galvanized conduit supports.
10. Raceways are not to be used with the bottom entry and exit style of installation.

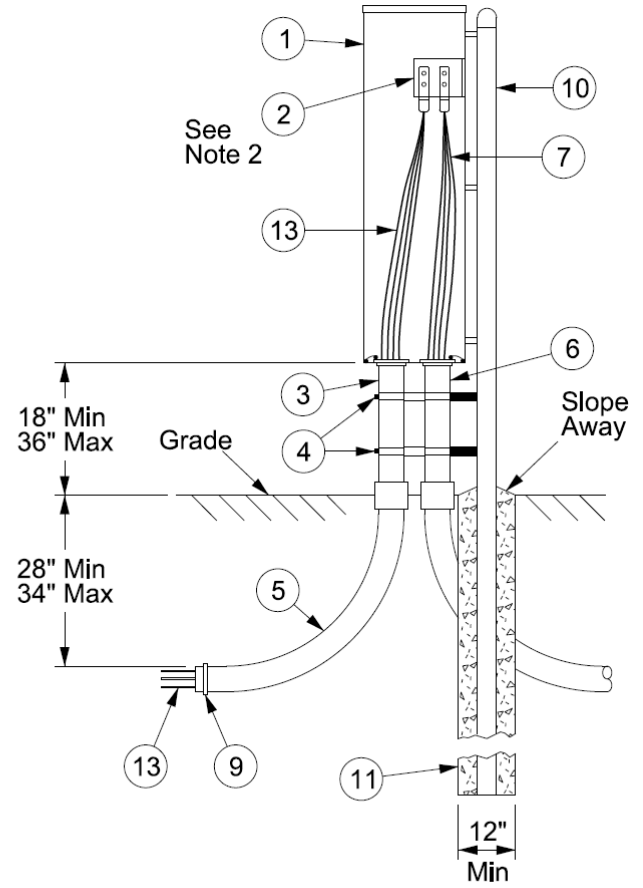
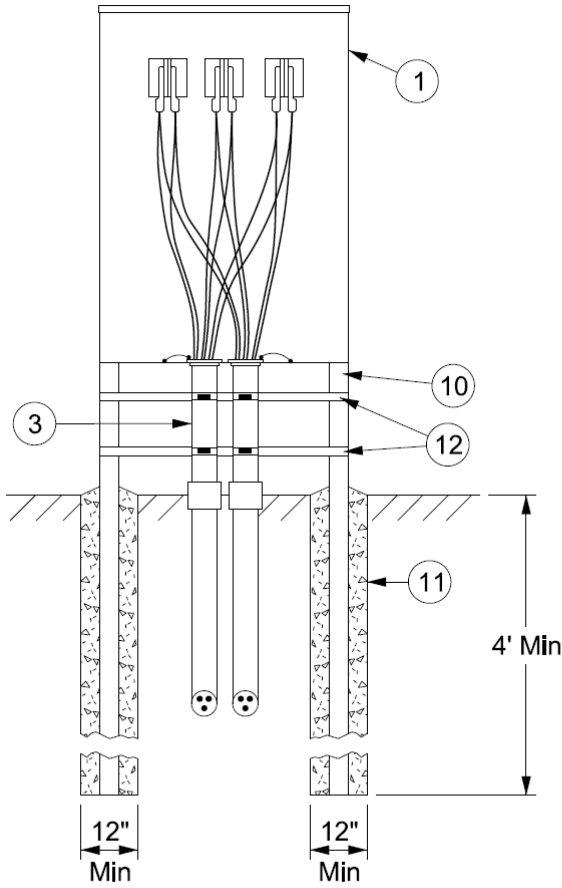

Direct Buried Service Lateral

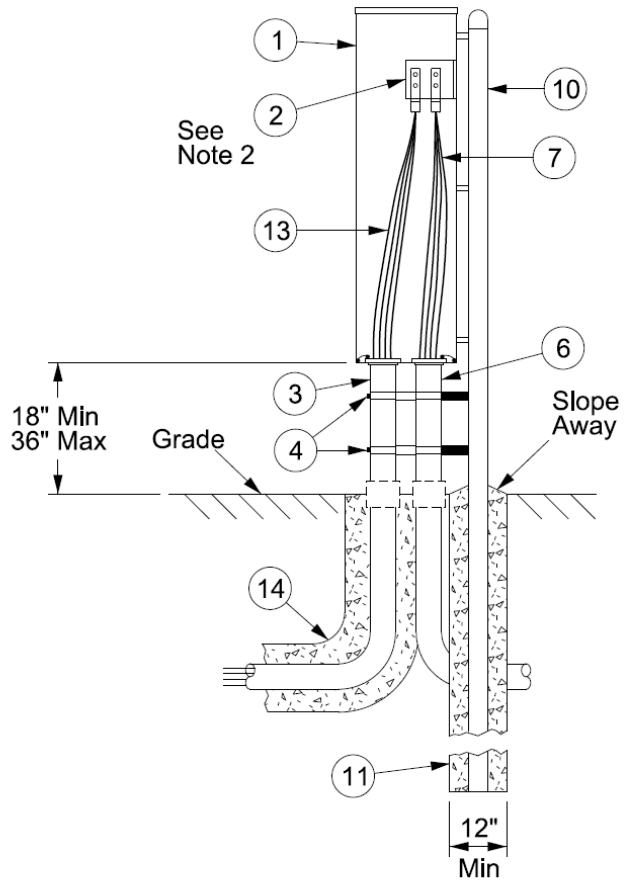
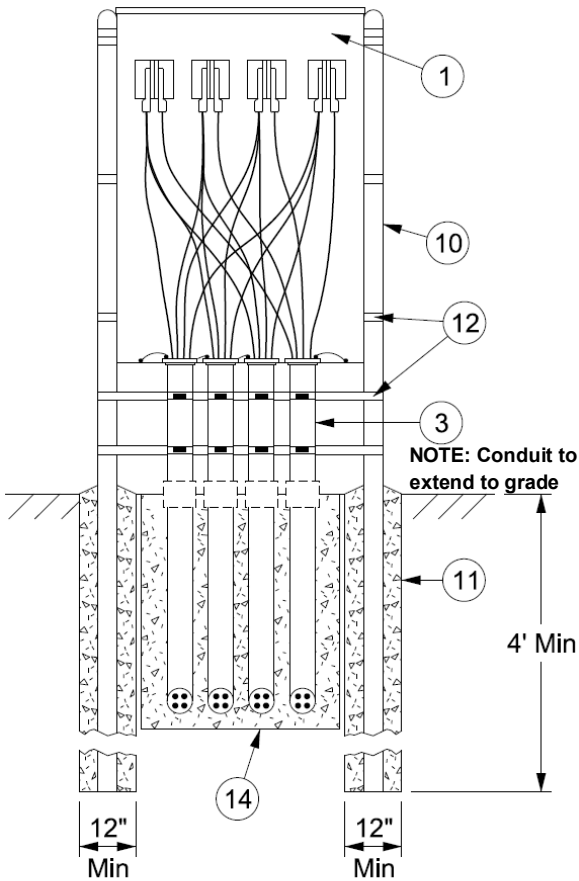

Concrete Encased Service Lateral

SERVICE TERMINATION IN A TERMINATION COMPARTMENT

PADMOUNTED – BOTTOM ENTRY AND EXIT

ALL 1Ø VOLTAGES, 400-800A

ALL 3Ø VOLTAGES, 400-4000A

Obtain acceptance for 1Ø installations larger than 400A from the Company

Customer furnishes and installs:

1. Company listed termination compartment (see Note 1 & D-22).
2. Termination pads (see Note 2).
3. Service lateral conduit 400-4000A (see Notes 3 & 4).
4. Service entrance conduit (see Note 4).
5. Service entrance conductors (see Note 5).
6. 4" 90° elbow with 36" radius (see Note 8).
7. Insulated conduit bushing.
8. Concrete pad (see Note 7).

Company furnishes and installs:

9. Service lateral with compression lug terminations (600A +) (see Note 6)
10. Conduit package.

Notes:

1. The termination compartment may be bonded to the neutral termination pad.
2. The termination pads are to be raised to their highest position.
3. Schedule 40 PVC, galvanized rigid, or IMC conduit shall extend to be slightly higher than level with the top of the concrete pad (no more than 3" higher). If used, metallic conduit shall be bonded. Reference U-3 for the number and proper size of the conduits and U-4 for conduit details. Contact the We Energies job representative for approval.
4. The customer service entrance conduits shall be located as shown on U-17 for the style of termination compartment used. The Company service lateral conductors are to terminate on the termination pads as per U-17.
5. The customer's service entrance conductors are to terminate on the termination pads as per U-17 and shall leave the termination compartment as a maximum of two circuits, regardless of the number of conductors per phase. They shall not share bolts with the service lateral.
6. The concrete pad shall be 6" thick and 3-5" wider and deeper than the termination compartment.
7. The 90° elbows shall face the transformer. See layout drawing provided by the Company.

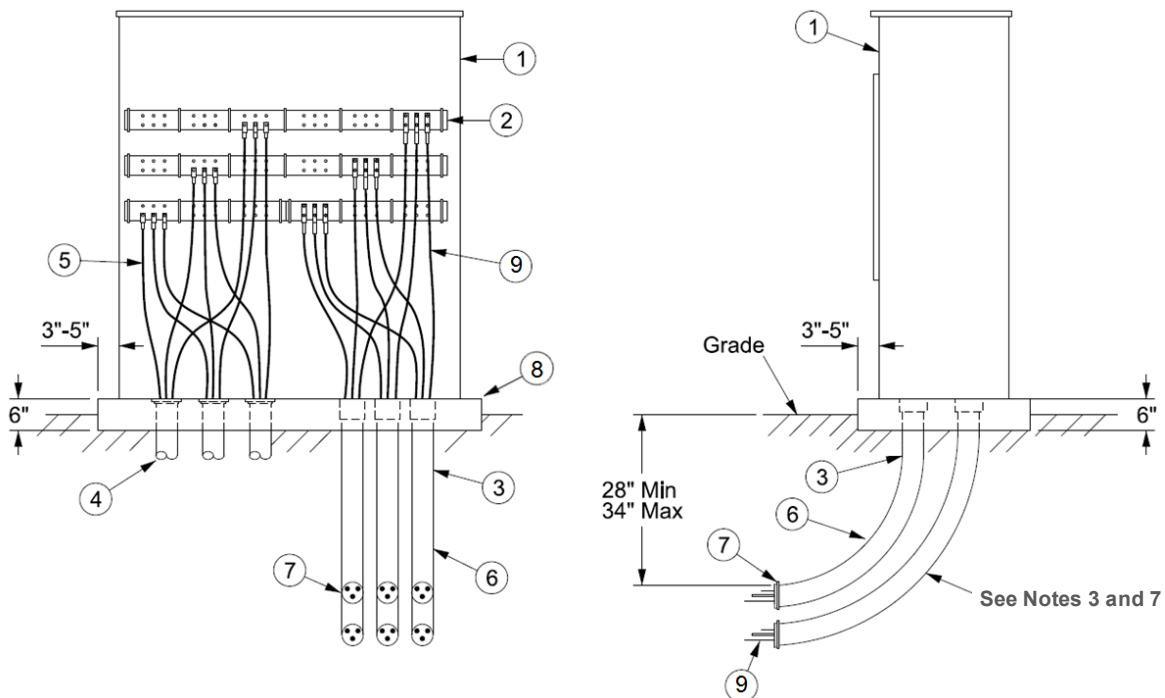

SERVICE TERMINATION IN A TERMINATION COMPARTMENT

CONCRETE ENCASED LATERAL – MULTI-METERED INSTALLATIONS

ALL 1Ø VOLTAGES, 400-800A

ALL 3Ø VOLTAGES, 400-3000A

Obtain acceptance for 1Ø installations larger than 400A from the Company

Customer furnishes and installs:

1. Company listed termination compartment (see Note 1 & D-18).
2. Service lateral conduit 400 – 3000A (see Note 2).
3. Conduit supports.
4. Service entrance conduit (see Note 4).
5. Service entrance conductors (see Note 5).
6. Bonding. Metallic conduit shall be bonded.

Company furnishes and installs:

7. Service lateral with compression lug terminations (600A +).
8. Conduit package.

Notes:

1. The termination compartment may be bonded to the neutral termination pad.
2. For concrete encased services 1600A or less, a raceway is preferred (see D-16 for approved raceways). For concrete encased service laterals, raceways shall extend 3" to 6" below final grade. If the raceway cannot be used, such as where the termination compartment is located in a paved area, conduit may be used; see Note 3 for conduit details.
3. Galvanized rigid or galvanized intermediate conduit with threaded ends and threaded fittings at the termination compartment are required. For concrete encased laterals, the lower ends are not required to be threaded. Conduits are to be located on 6" centers and extend to grade level. Reference page U-3 for the proper number and size of the conduits and U-4 for conduit details. Contact the We Energies job representative for approval.
4. If the service entrance conduits are located above the termination pads, watertight hubs or sealing locknuts are required. When the service entrance conduit enter box at the top, watertight hubs are required.
5. The customer's service entrance conductors shall leave the termination compartment as a maximum of two circuits, regardless of the number of conductors per phase.

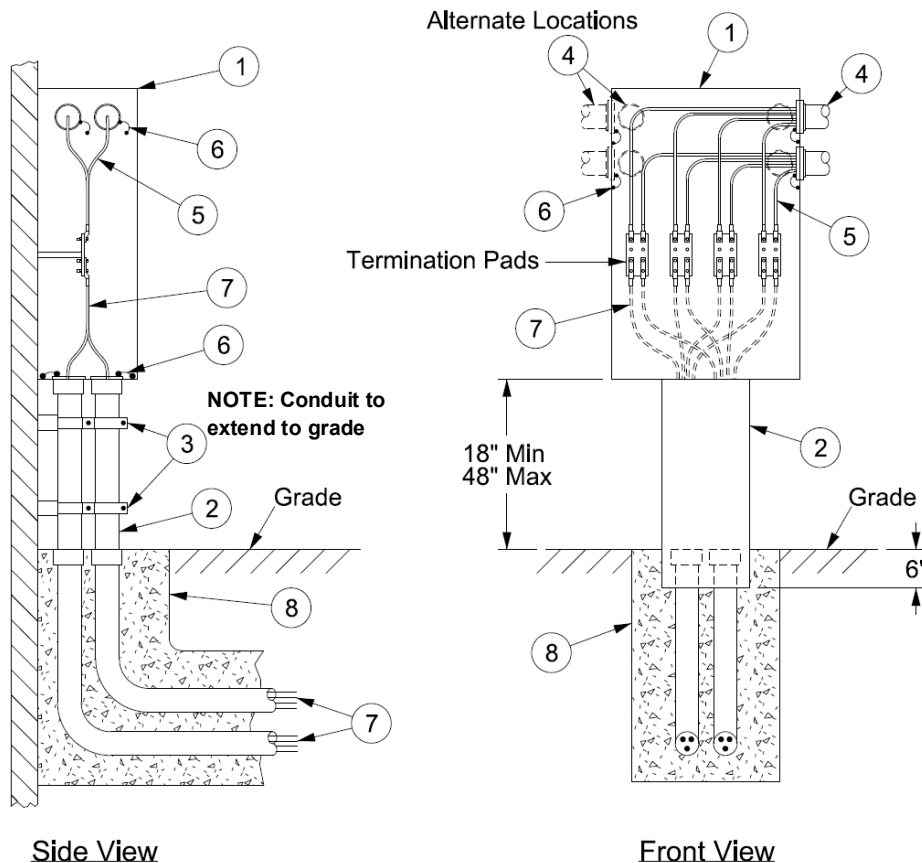

SERVICE TERMINATION IN A TERMINATION COMPARTMENT

BUILDING WITHOUT A BASEMENT – FIRST FLOOR INSTALLATION – MULTI-METERED INSTALLATIONS

ALL 1Ø VOLTAGES, 400-800A

ALL 3Ø VOLTAGES, 400-3000A

Obtain acceptance for 1Ø installations larger than 400A from the Company

Company furnishes and installs:

1. Company listed termination compartment (see Note 1 & D-18).
2. Service lateral conduit (see Note 2).
3. 4" I.D. 90° elbow (see Note 2).
4. Steel reinforcing rods, 5/8" x 6'.
5. Conduit spacers.
6. Continuous concrete envelope with a minimum of 3" of concrete on all sides.
7. Bonding. Metallic conduit shall be bonded.
8. Service entrance conduit.
9. Service entrance conductors (see Note 3).
10. Temporary watertight end caps.

Company furnishes and installs

11. Service entrance conduit, coupling, & concrete envelope.
12. Service lateral with compression lug terminations (600A +).

Notes:

1. The termination compartment may be bonded to the neutral termination pad.
2. Galvanized rigid or galvanized intermediate conduit with threaded ends, or rigid nonmetallic schedule 40 PVC is acceptable. Reference page U-3 for the proper number and size of the conduits required and U-4 for conduit details. Contact the We Energies job representative for approval.
3. The customer's service entrance conductors shall leave the termination compartment as a maximum of 2 circuits, regardless of the number of phases per conductor.
4. Conduit for direct buried installations shall extend a minimum of 12" into undisturbed earth.

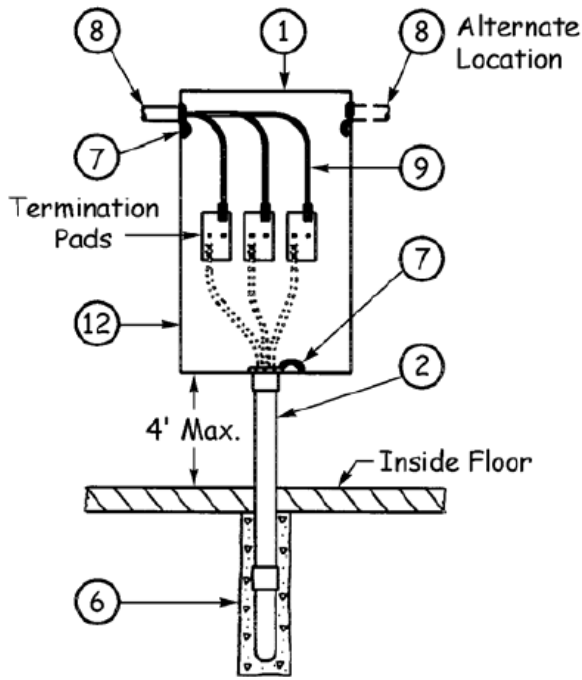

Front View

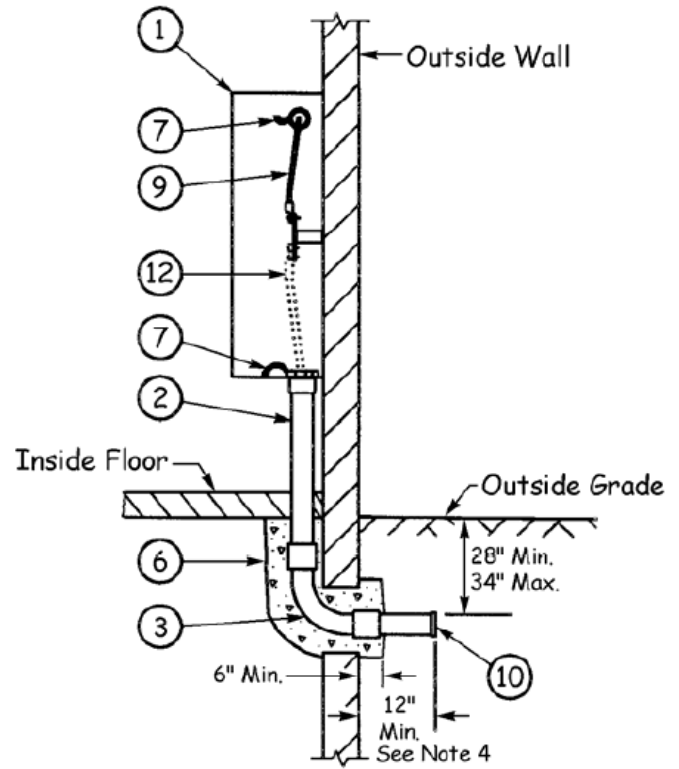

Side View

WITH DIRECT BURIED SERVICE LATERAL

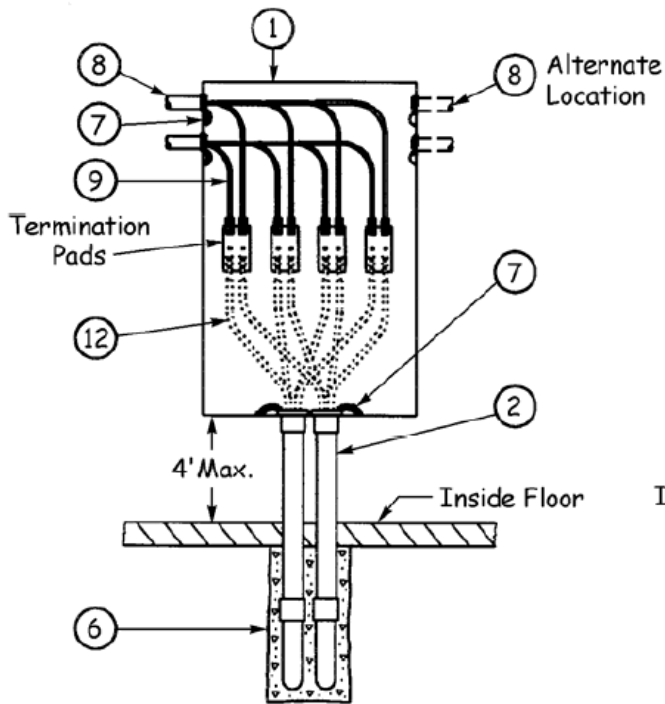

Front View

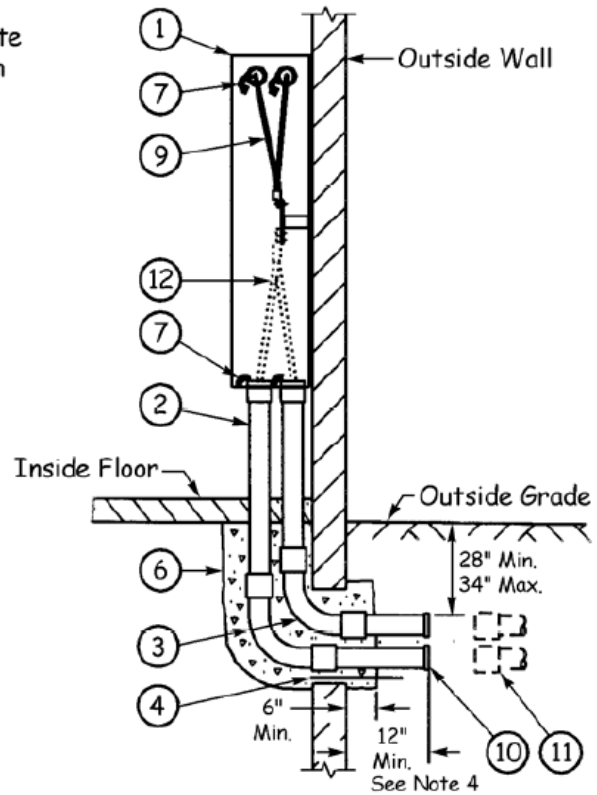

Side View

WITH CONCRETE ENCASED SERVICE LATERAL

SERVICE TERMINATION IN A TERMINATION COMPARTMENT

CONCRETE ENCASED LATERAL – LOCATED BELOW GRADE

CONDUIT AND MANHOLE SYSTEM ONLY

ALL 1Ø VOLTAGES, 400-800A

ALL 3Ø VOLTAGES, 400-3000A

REQUIRES COMPANY APPROVAL (SEE NOTE 4)

Customer furnishes and installs:

1. Company listed termination compartment (see Note 1 & D-20).
2. Service lateral conduit (See Note 2).
3. Terminal adapter with locknuts and insulated bushing.
4. Steel reinforcing rods, 5/8" x 6'.
5. Continuous concrete envelope with a minimum of 3" of concrete on all sides.
6. Service entrance conduit. Metallic conduit shall be bonded.
7. Service entrance conductors (see Note 3).
8. Temporary watertight end cap.

Company furnishes and installs:

9. Service lateral conduit, concrete encased.
10. Service lateral with compression lug terminations (600A +).

Notes:

1. The termination compartment may be bonded to the neutral termination pad. Only termination compartments listed on Page D-20 as for use below grade are to be used. These units have termination pads that are adjustable to obtain the 24" min. from the top of the pad to the bottom of the conduits.
2. 4" rigid nonmetallic schedule 40 PVC conduit per NEMA standard TC-2. Conduits are to be arranged horizontally and 6" on center as shown Reference page U-3 for the proper number and size of the conduits required and U-4 for conduit details. Contact the We Energies job representative for approval.
3. The customer's service entrance conductors shall leave the termination compartment as a maximum of two circuits, regardless of the number of conductors per phase.
4. **Send copies of the drawings of the switchgear termination and metering compartments to the local We Energies job representative for acceptance prior to any construction.**

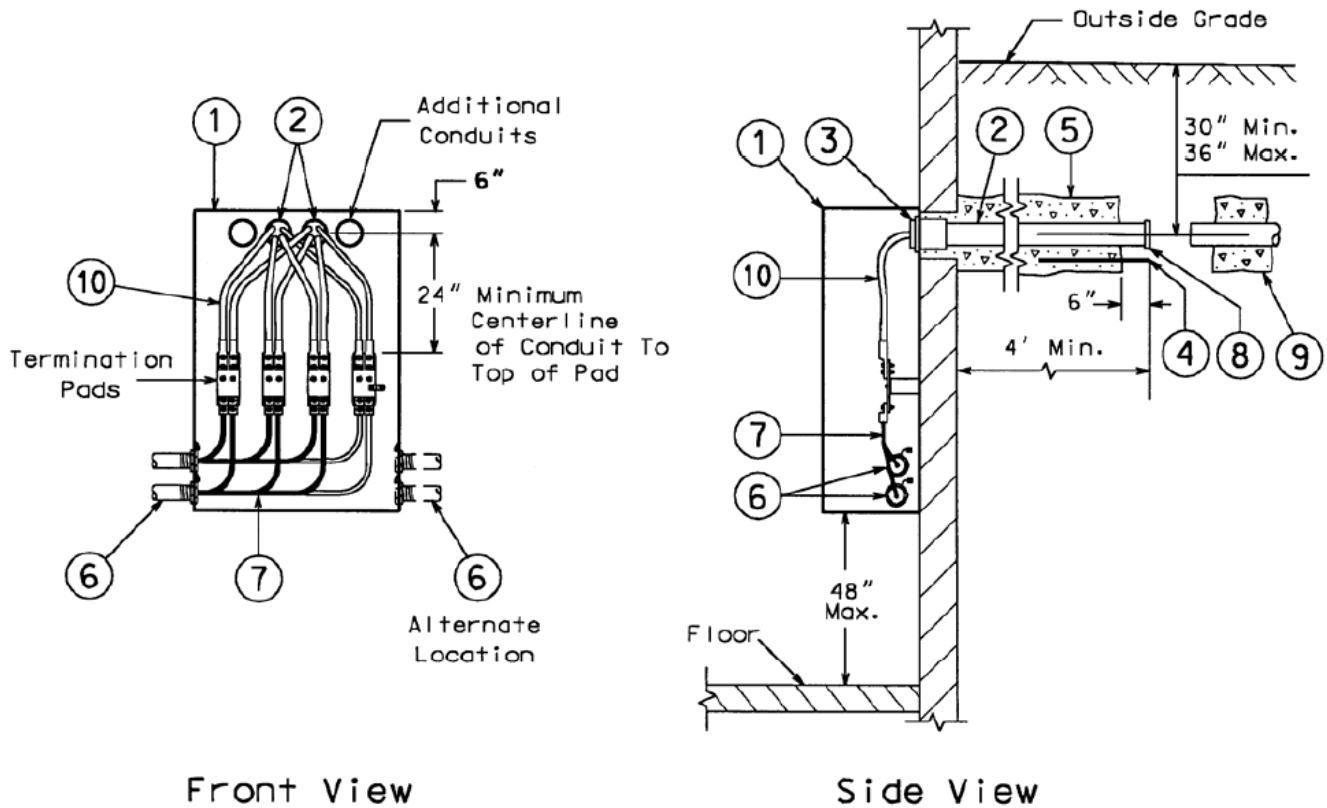

SERVICE TERMINATION IN A TERMINATION COMPARTMENT

FREE STANDING SWITCHGEAR – LOCATED BELOW GRADE – FOR AREAS SERVED BY CONDUIT AND CABLE ONLY

ALL 3Ø VOLTAGES, 2000-4000A

REQUIRES COMPANY APPROVAL (SEE NOTE 5)

Customer furnishes and installs:

1. Completely enclosed termination compartment with rigidly supported bus bars, located and drilled as shown (see Notes 1 through 4).
2. 4" schedule 40 PVC conduit, concrete encased. (see Note 8).
3. Temporary watertight end caps.
4. Reinforcing rods (epoxy coated re-bar).

Company furnishes and installs:

5. Service lateral conduit and concrete envelope (not shown). We Energies does not lace cables.
6. Service lateral with compression lug terminations (not shown).

Notes:

1. Rigidly supported barriers shall separate the termination compartment from other compartments.
2. Front panels are to be removable, sealable, have hasps for padlocking, and when removed shall leave a clear and unobstructed opening exposing only the service lateral termination area. All other panels shall be installed in their original position on the switchgear prior to We Energies terminating cables.
3. Only the service lateral conductors are allowed in this termination compartment. The grounding electrode conductor shall NOT pass through, or terminate in, this compartment; nor shall bonding of the neutral and grounding buses be done in this compartment.
4. Bus work shall be labeled in each compartment to easily identify phases.
5. **Send copies of the drawings of the switchgear termination and metering compartments to the local We Energies job representative for acceptance prior to any construction.**
6. The dimension shown is from the bottom of the conduit to the top hole in the bus bar. For 3Ø, 3 wire installations, omit the neutral bus and use the 40" dimension.
7. See pages M-20 and M-21 for metering details.
8. Reference U-4 for conduit details and width table. Conduit shall be installed so the duct package width is parallel with the bus. See the drawings below.

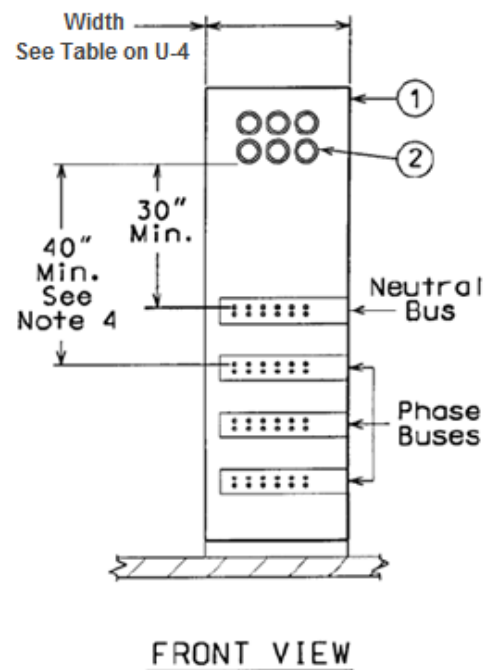
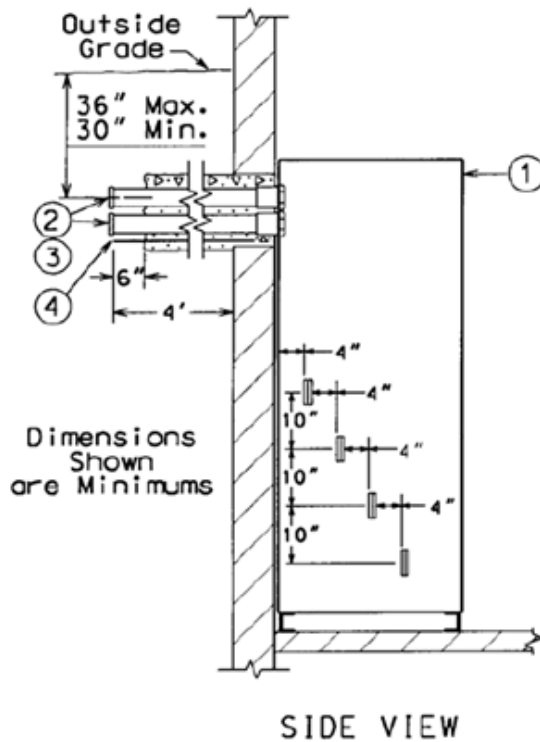

SERVICE TERMINATION IN A TERMINATION COMPARTMENT

FREE STANDING SWITCHGEAR – LOCATED ON FIRST FLOOR OR ABOVE

ALL 3Ø VOLTAGES, 2000-4000A

REQUIRES COMPANY APPROVAL (SEE NOTE 5)

Customer furnishes and installs:

1. Completely enclosed termination compartment with rigidly supported bus bars, located and drilled as shown (see Notes 1 through 4).
2. 4" schedule 40 PVC conduit, concrete encased. (see Note 8).
3. Temporary watertight end caps.
4. Reinforcing rods (epoxy coated re-bar).
5. 4" schedule 40 PVC, 90° elbows with 36" radius.

Company furnishes and installs:

6. Service lateral conduit and concrete envelope (not shown). We Energies does not lace cables.
7. Service lateral with compression lug terminations (not shown).

Notes:

1. Rigidly supported barriers shall separate the termination compartment from other compartments.
2. Front panels are to be removable, sealable, have hasps for padlocking, and when removed shall leave a clear and unobstructed opening exposing only the service lateral termination area. All other panels shall be installed in their original position on the switchgear prior to We Energies terminating cables.
3. Only the service lateral conductors are allowed in this termination compartment. The grounding electrode conductor shall NOT pass through, or terminate in, this compartment; nor shall bonding of the neutral and grounding buses be done in this compartment.
4. Bus work shall be labeled in each compartment to easily identify phases.
5. **Send copies of the drawings of the switchgear termination and metering compartments to the local We Energies job representative for acceptance prior to any construction.**
6. The dimension shown is from the top of the conduit to the lower hole in the bus bar. For 3Ø, 3 wire installations, omit the neutral bus and use the 40" dimension.
7. The preferred termination of service laterals is on the outside of a building (or structure). Service laterals that terminate inside of a building shall terminate immediately upon entering as shown in this manual. The raceway for service laterals under or through a building shall not extend longer than 8' after penetrating the outside wall; this is a We Energies requirement (see U-2 Note 3) in addition to the State of Wisconsin requirement. The only bend allowed in the duct package is the 90° bend to enter the termination compartment.
8. Where the termination compartment is located on a mezzanine, a continuous duct package must be installed with a maximum distance of 14' from final grade to the bottom of the termination compartment.
9. See pages M-20 and M-21 for metering details.
9. Reference U-4 for conduit details and width table. Conduit shall be installed so the duct package width is parallel with the bus. See the drawings below.

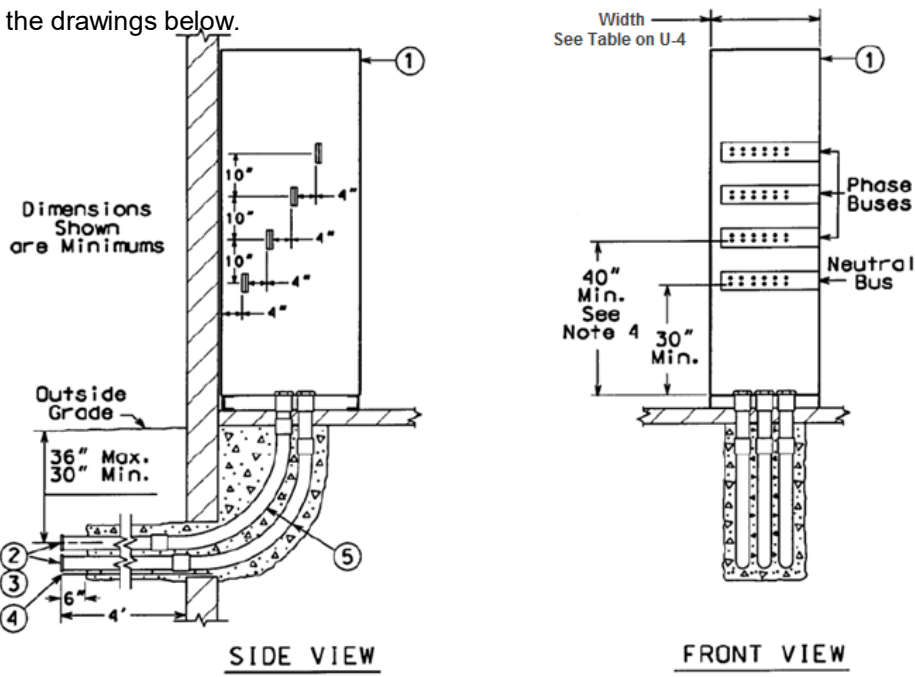

COMMUNICATION TOWERS

POLICY ON SERVICES

NEW SERVICES

We Energies policy is to provide one electric service to each tower site. This service must be sized to accommodate present and future carriers that have space on the tower with a meter position for each carrier. Applications for service to tower sites shall include information on each tower's capacity (i.e. total number of carriers the tower will accommodate). This information is a requirement for electric service to the tower site.

If additional carriers are allowed space on the tower and the size of the service or number of meter sockets need to be increased, the owner shall be responsible for increasing the size of the service and/or the number of meter sockets. Additional services **laterals** are not permitted.

EXISTING SERVICES

For existing towers, the owner will **need to request to** install a multi-position metering bank to serve the **total** number of tenants that may attach to the tower in the future.

COMMUNICATION TOWERS

SERVICE TERMINATION IN A FREE STANDING MULTI-POSITION METER SOCKET – DIRECT BURIED LATERAL

1Ø 120/240 VOLTS, 0-800A
0-200A PER METER, 2-6 METERS

Customer furnishes and installs:

1. Service entrance conduit.
2. Service entrance conductors.
3. Metallic conduit shall be bonded.
4. Company listed 2 – 6 position meter socket (see Notes 1 & 4 and sheet D-8).
5. Service lateral conduit (see Note 2).
6. Insulated conduit bushings (see Note 3).
7. 4" galvanized rigid or IMC 90° elbow with 24" radius. (see Note 6)
8. Galvanized steel framing channel, 1-5/8" x 1-5/8" x 12 Ga.

Customer furnishes and installs:

9. Conduit clamps.
10. 3' galvanized rigid with galvanized end cap (see Note 5).
11. Concrete footing (12" minimum hole size).

Company furnishes and installs:

12. Service lateral.
13. Watthour meters.

Notes:

1. Separate cable compartment is provided for the Company's service lateral cables only.
2. 4" galvanized rigid or galvanized intermediate conduit with threaded ends and fittings. Reference page U-3 for the proper number and size of the conduits required and U-4 for conduit details. Contact the We Energies job representative for approval.
3. Service lateral conduits shall extend underground to a point outside of fenced area and have temporary waterproof end caps to prevent the accumulation of water, ice, and other foreign matter inside the conduits.
4. Each meter position shall be marked on the outside of the socket or by the breaker (if available) with the address of the unit served. If the marking is on the outside of a removable cover, it shall also be marked on the inside of the meter socket in a visible location. This marking shall also be placed on the corresponding distribution panel(s). The marking shall be a permanent label with ½" block letters and may consist of individual self-stick letters or numbers, suitable for the location so as to be considered permanent.
5. As an alternative item to Item 10 above, 4" x 4" x 3/8" galvanized steel angle may be used.
6. **If conduit extends past the 90 degree elbow, transition to schedule 40 PVC. Customer is to match burial depth of the company. Please send conduit plans to the company for acceptance.**

